



# EVOLUTION

MANUALE DI ISTRUZIONE

INSTRUCTION MANUAL

使用手册

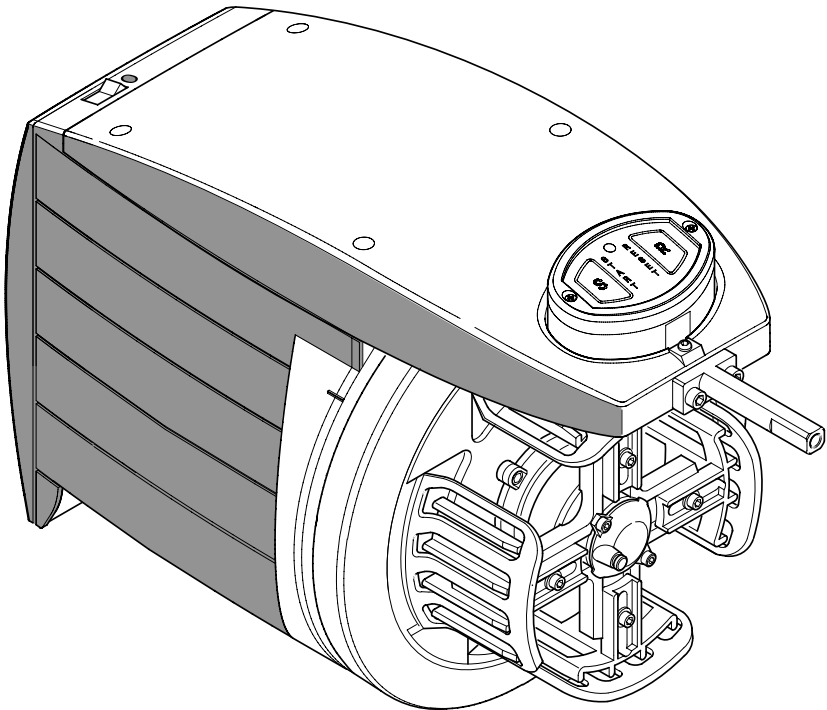

PREMISURATORE DI TRAMA A SPIRE SEPARATE REGOLABILI

WEFT PRE-MEASURING WINDER WITH ADJUSTABLE SEPARATE COILS

纬纱预测络纱机



Scope of supply: Design, manufacture and after sales service of yarn and weft feeders, measuring winders, stands, creels and oil systems for textile machinery.

TRADUZIONI DELLE ISTRUZIONI ORIGINALI.  
TRANSLATION OF THE ORIGINAL INSTRUCTIONS.  
原始使用说明的翻译.

L.G.L. Electronics is gratified by your choice  
and thanks you for the preference.

# Weft pre-measuring winder INSTRUCTION MANUAL: EVOLUTION

ISSUED BY:

Service  
Manager

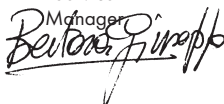

Date: 01/03/2017

APPROVED BY:

Technical  
Manager



Date: 01/03/2017

# WARNINGS!



1) Switch off the power supply box mains and the weft pre-measuring winder before starting any connection, servicing or replacement operation.



2) The weft pre-measuring winder must be switched off before carrying out any adjustment.



3) If the weft pre-measuring winder is fitted with a kit for pneumatic threading, discharge all the compressed air before removing the rear cover or the top panel.



4) During standard loom operation, the weft pre-measuring winder may suddenly start up without prior warning. Caution is required due to moving parts.



5) Use of only the original L.G.L. Electronics spare parts and accessories is recommended.



6) The electronic parts can only be repaired by suitably trained personnel, that has been regularly authorised by L.G.L. Electronics accordingly.



7) Weft pre-measuring winders that are moved from a warehouse into a warmer weaving mill environment may develop condensation due to the temperature differences. Please wait until they are completely dry before connecting them up. Failure to do so may damage the electronic components.



8) When handling the device, even if transfer is brief and performed on-site, please always make sure that the electromagnet/ photocell unit is raised so that the electromagnet pin is kept in a higher position compared to that of the winding unit.

	page
<b>1 GENERAL FEATURES</b>	<b>51</b>
1.1 Intended use	51
1.2 Main parts	51
1.3 Operational features	52
1.4 Technical specifications	53
1.5 Handling and storage instructions	54
1.6 Overall dimensions	55
1.7 How to determine the weft yarn twist	55
<b>2 CONTROLS AND ADJUSTMENTS</b>	<b>56</b>
<b>3 INSTALLATION</b>	<b>58</b>
3.1 Power supply box installation	58
3.2 Installation of the weft pre-measuring winder	61
<b>4 COMMISSIONING THE UNIT</b>	<b>62</b>
4.1 Input sensor	62
4.2 How to set the length of the weft	64
4.3 Threading and winding in the winding reserve	66
4.4 Adjusting the coil separation	67
4.5 Restoring the winding reserve	68
<b>5 MAINTENANCE AND COMPONENT REPLACEMENTS</b>	<b>69</b>
5.1 How to dismantle the winding group	69
5.2 Replacing the input sensor	72
5.3 Replacing the main L.G.L. 103 electronic control board	73
5.4 Replacing the electromagnet/photocell unit and relative L.G.L. 114 control board	75
5.5 Replacing the photocell and relative L.G.L. 112 board	77

# INDEX

	page
<b>6 ELECTRICAL SPECIFICATIONS</b>	78
6.1 Power supply box fuses	78
6.2 Pre-measuring winder main electronic control board fuse	78
<b>7 PUSH-PULL</b>	79
7.1 Description	79
7.2 Functions	79
7.3 Recommended use	79
7.4 Assembly	80
7.5 Start-up	82
7.6 How to replace or reposition the brake	83
<b>9 TROUBLE SHOOTING</b>	87
<b>10 STRIPPING AND SCRAPPING</b>	90
<b>ACCESSORIES</b>	91
<b>SPARE PARTS</b>	101
<b>POWER SUPPLY BOX CONNECTION DRAWING</b>	109

# 1 - GENERAL FEATURES

## 1.1 INTENDED USE

### EVOLUTION

**EVOLUTION** is a weft pre-measuring winder that forms 0 to 2,5 mm **separate coil** intervals for either “S” or “Z” twist yarns and for use on either air-jet or water-jet weaving machines.

It operates with yarn counts ranging from **20 den** (fine weft counts) to **2 Nm** (thick weft counts), providing the loom with a set weft insertion length.

## 1.2 MAIN PARTS

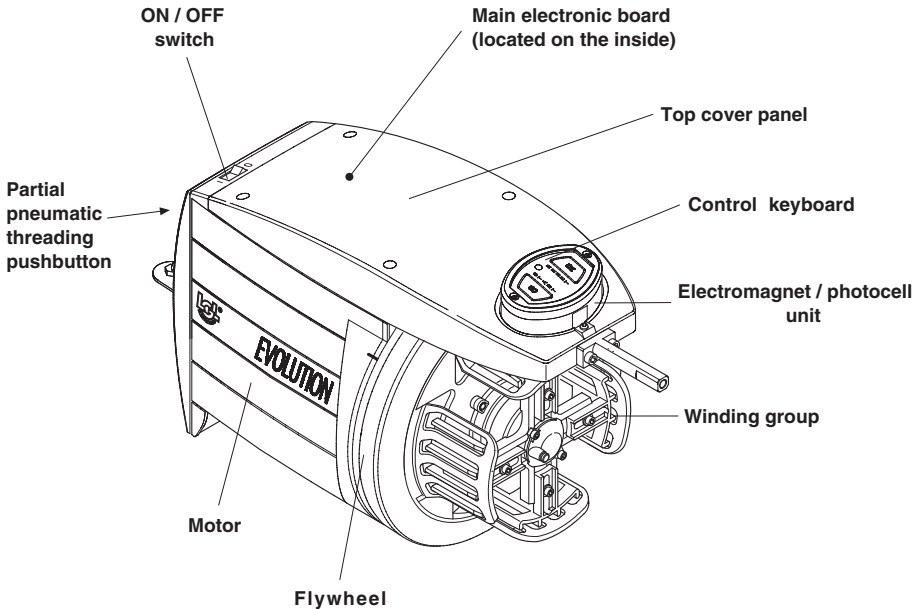

# 1 - GENERAL FEATURES

## 1.3 OPERATIONAL FEATURES

- Automatic speed adjustment to suit the loom's weft quantity requirements.
- Photocells counting the number of coils released.
- Weft-length pre-measuring feature set by varying the diameter of the winding group and the number of coils released at each insertion. Sense of rotation can be inverted for **S** or **Z** twist yarns.
- Half-duplex dialogue with the weaving loom.
- Operating parameters programming option with display of set parameters either directly on the loom controls or via PC or optional Pocket device.
- Partial and final pneumatic threading.
- Input sensor (optional), featuring the following functions:
  - Automatic loom and pre-measuring winder alarm/stop function if no weft is detected at pre-measuring winder inlet (broken weft or end of yarn reel).
  - Automatic exclusion of broken wefts through the pre-measuring winder stop function without having to stop the loom if no weft is detected at pre-measuring winder inlet (broken weft or end of yarn reel).

*N.B.: The “broken weft exclusion” function is only possible if the loom is appropriately equipped for it.*
- Optional fitting of the Push-Pull electronic weft-brake.



# 1 - GENERAL FEATURES

## 1.4 TECHNICAL SPECIFICATIONS

- The pre-measuring winder's power supply box is supplied separately by L.G.L. Electronics.  
Supply voltage: **VA= 550 V= 200/600 Hz= 50/60**
- Automatic weft feeding speed adjustment up to a maximum of **3000 m/min** with weft mixing or up to **2000 m/min** with one colour.
- Three-phase asynchronous reduced inertia motor, maintenance free.  
Motor data:  
Maximum power: **200 W**      Average absorbed power: **70 W**  
Torque: variable, from **0.15 Nm** to **0.9 Nm**      Max. speed: **6,500 rpm**
- Equivalent continuous A-weighted sound pressure level at maximum speed: **Lcq = 79.1 dB (A)**
- Sound power level: **Lw(A) = 82.2 dB (A)**
- Recommended pneumatic circuit pressure: **5 bar** minimum, **7 bar** maximum.
- Operating conditions:  
Room temperature: from **+10** to **+40 °C**  
Maximum humidity: **95%**
- The machine complies with all significant requirements as provided for in the EC Directives nos. 98/37/EC, 73/23/EC and 89/336/EC.  
Harmonised regulations implemented comply with:  
EN60204-1, EN50081-2, EN61000-6-2, EN292, ISO EN3746.

# 1 - GENERAL FEATURES

## 1.5 HANDLING AND STORAGE INSTRUCTIONS

*Never pick the weft pre-measuring winder up by its front end (winding group and/or electromagnet/photocell unit).*

**YES**

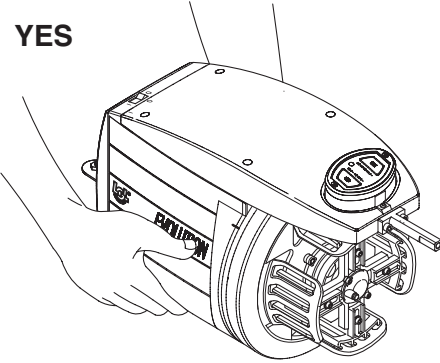

**NO**

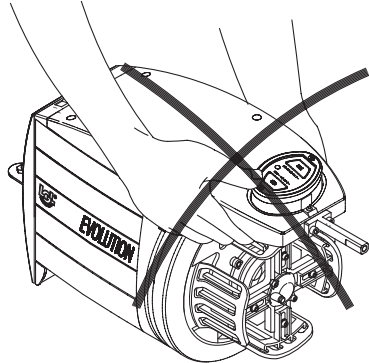

*When handling the device, even if movements are brief and performed on-site, always make sure that the electromagnet/photocell unit is raised so that the electromagnet pin is kept in a higher position compared to that of the winding unit.*

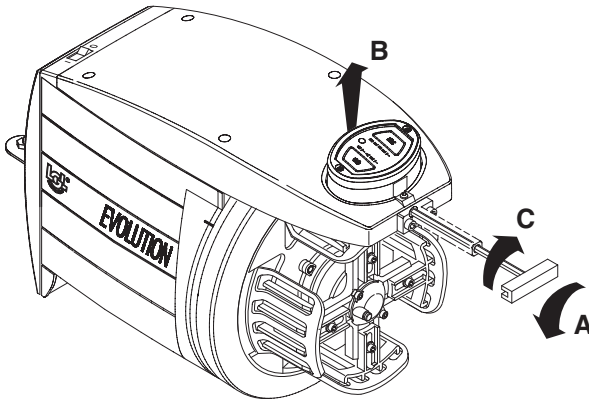

The weft pre-measuring winders are supplied in appropriate polystyrene casings, please store the casings away for use during any subsequent handling.

Storing conditions:

Temperature: from  $-30$  to  $+70$  °C.

Maximum humidity: 95%.

# 1 - GENERAL FEATURES

## 1.6 OVERALL DIMENSIONS

### EVOLUTION

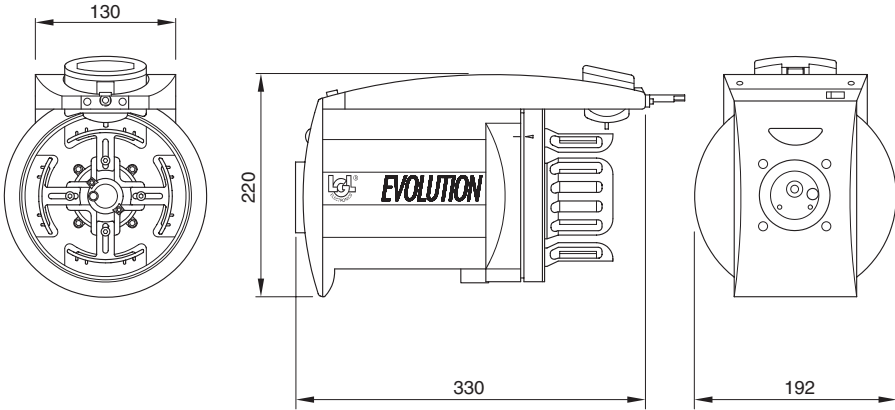

Weight: 9.5 kg

## 1.7 HOW TO DETERMINE THE WEFT YARN TWIST

Hold weft yarn **T** at one end and hold the other end between your thumb and forefinger. Rotate the yarn in the direction as shown by the arrow **L**.  
If the weft yarn gathers more twist, it is an **S** twist yarn.  
If the weft loses twist, it is a **Z** twist yarn .

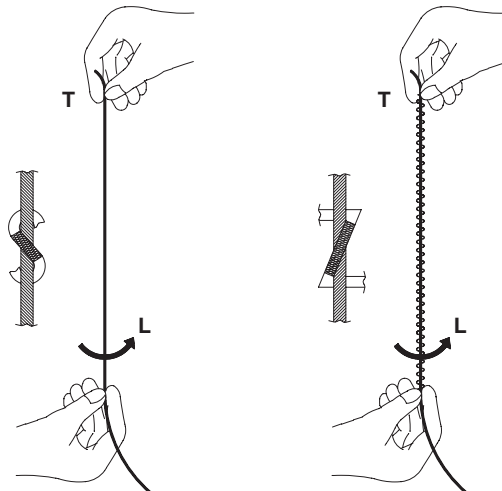

## 2 - CONTROLS AND ADJUSTMENTS

### EVOLUTION

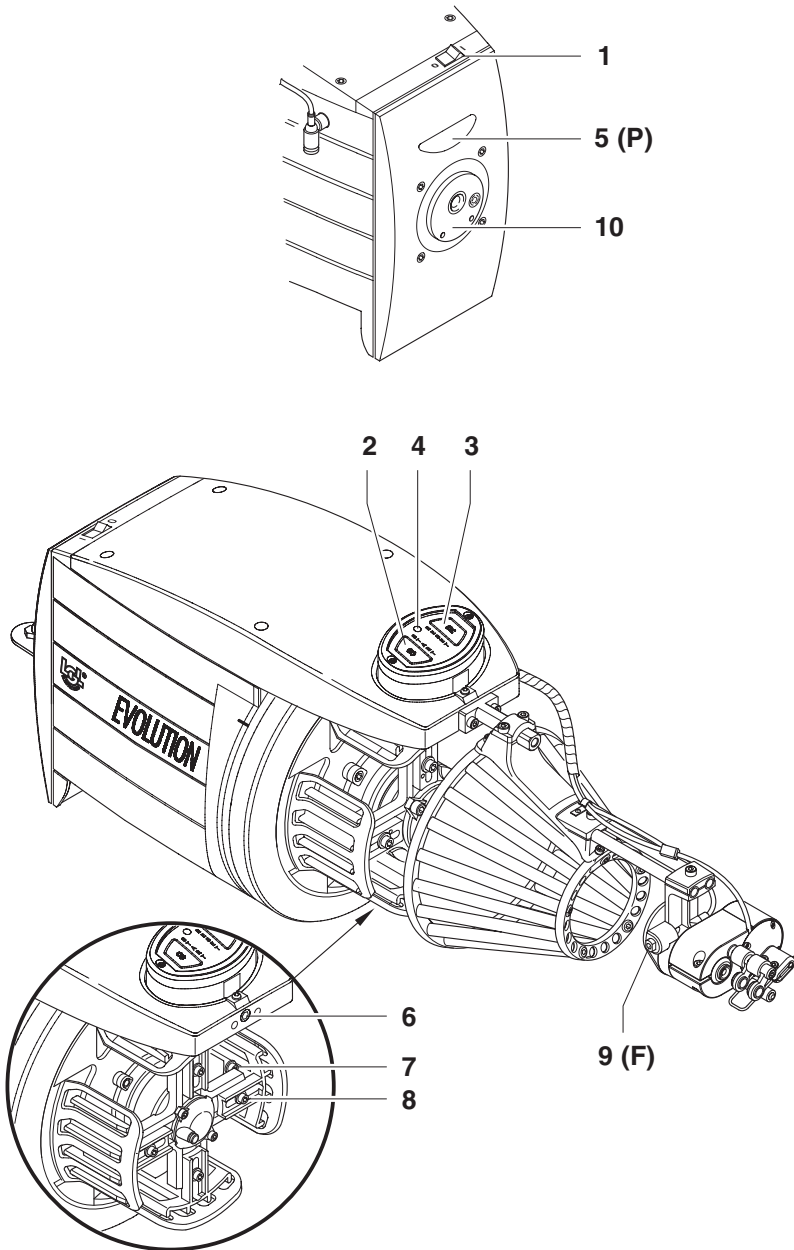

## 2 - CONTROLS AND ADJUSTMENTS

CONTROLS / ADJUSTMENTS		FUNCTION
1	<b>O-I SWITCH</b>	<ul style="list-style-type: none"> <li>• Turns the weft pre-measuring winder ON and OFF.</li> </ul>
2	<b>START KEY</b>	<ul style="list-style-type: none"> <li>• Actuates the winding reserve wind-in function.</li> </ul>
3	<b>RESET KEY</b>	<ul style="list-style-type: none"> <li>• Actuates the electromagnet. With the weft pre-measuring winder on and the loom stopped it enables: <ul style="list-style-type: none"> <li>- removal of the winding reserve if pressed for longer than 2 sec.</li> <li>- release of a set number of coils (the standard number being one coil) when it is pressed and released quickly.</li> </ul> </li> </ul>
4	<b>LED</b>	<ul style="list-style-type: none"> <li>• This led comes on and stays on if all functions regularly when the pre-measuring winder is switched on.</li> <li>• This led will flash if any type of failure arises.</li> </ul>
5	<b>'P' PUSHBUTTON</b>	<ul style="list-style-type: none"> <li>• The 'P' pushbutton will activate the pneumatic threading function for partial pneumatic threading.</li> </ul>
9	<b>'F' PUSHBUTTON</b>	<ul style="list-style-type: none"> <li>• The 'P' pushbutton will activate the pneumatic threading function for final pneumatic threading.</li> </ul>
6	<b>ELECTROMAGNET / PHOTOCCELL UNIT HEIGHT ADJUSTMENT SCREW</b>	
7,8	<b>WINDING GROUP DIAMETER ADJUSTMENT SCREW</b>	
10	<b>INPUT SENSOR</b>	<ul style="list-style-type: none"> <li>• Detects whether weft is present at the pre-measuring winder input.</li> </ul>

# 3 - INSTALLATION

## 3.1 POWER SUPPLY BOX INSTALLATION

The following steps are required to install the power supply box:

1) Fix the power supply box at minimum 30 cm above floor level to the support, using the clamp provided.

2) ***Please make sure that the power supply box is suited to the mains supply voltage.***

*The mains supply voltage required for the power box is specified on the rating plate located above the main switch.*

If the mains voltage differs from the power supply box rating, open the box and connect the wires from the switch to the correct input on the transformer.

3) Connect up the power supply box's power supply cable to the three-phase mains line.

Should the power supply box be supplied without a cable, it should be connected to the power mains line by means of a 4-conductor cable. The section of each conductor must not be less than 1,5 mm<sup>2</sup>.

The three phases in the mains line must be connected up to terminals **L1**, **L2** and **L3**. Connect the earth wire up to terminal **PE**.

For the connections, please consult the drawing enclosed in the box. Go to page **109** to consult the power supply box connection drawing.

***N.B.: Please make all connections to the three-phase mains line downstream of the loom's main switch so that said main switch can also act as a switch for the pre-measuring winders fitted onto the loom.***

4) Connect up the power supply box earth cable to the box's stand (the connection must be carried out as shown in detail **A** of the figure on the next page).



***Connect up the earthing plait between the creel and the loom (as shown in the illustration).***

### CAUTION!

**Switch off the loom's power supply box before proceeding with any connection whatsoever.**

# 3 - INSTALLATION

**RS485 power supply box**

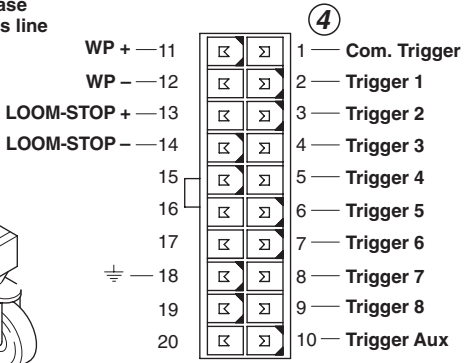
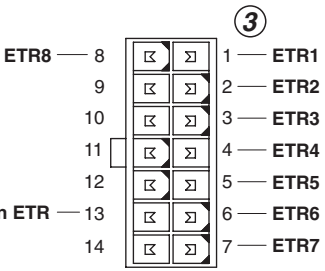
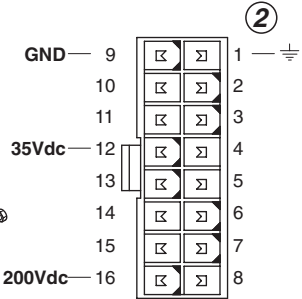
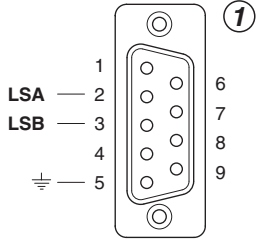
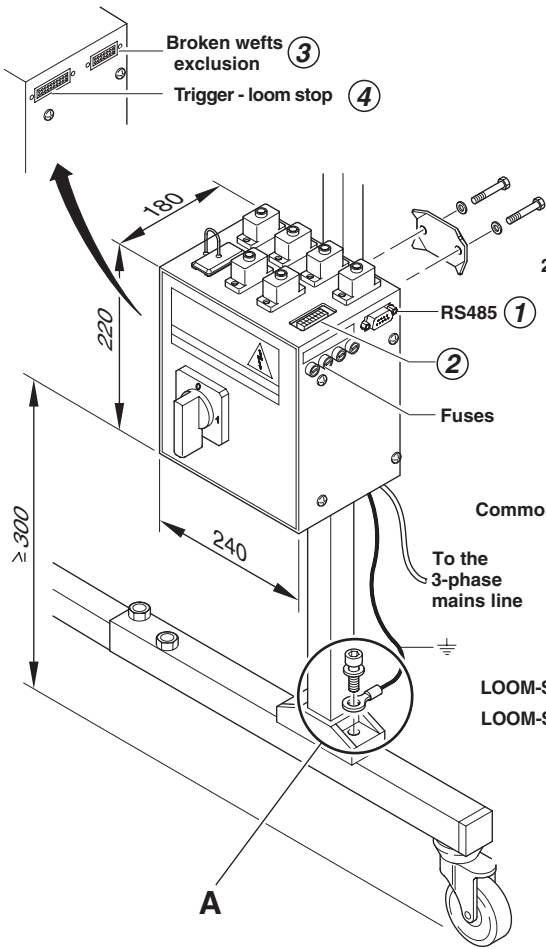
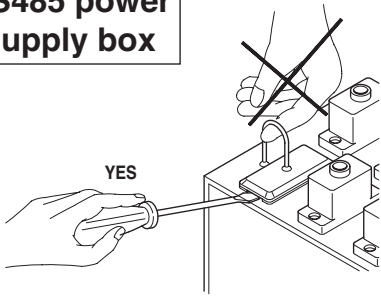

# 3 - INSTALLATION

**CAN-BUS**  
power supply box

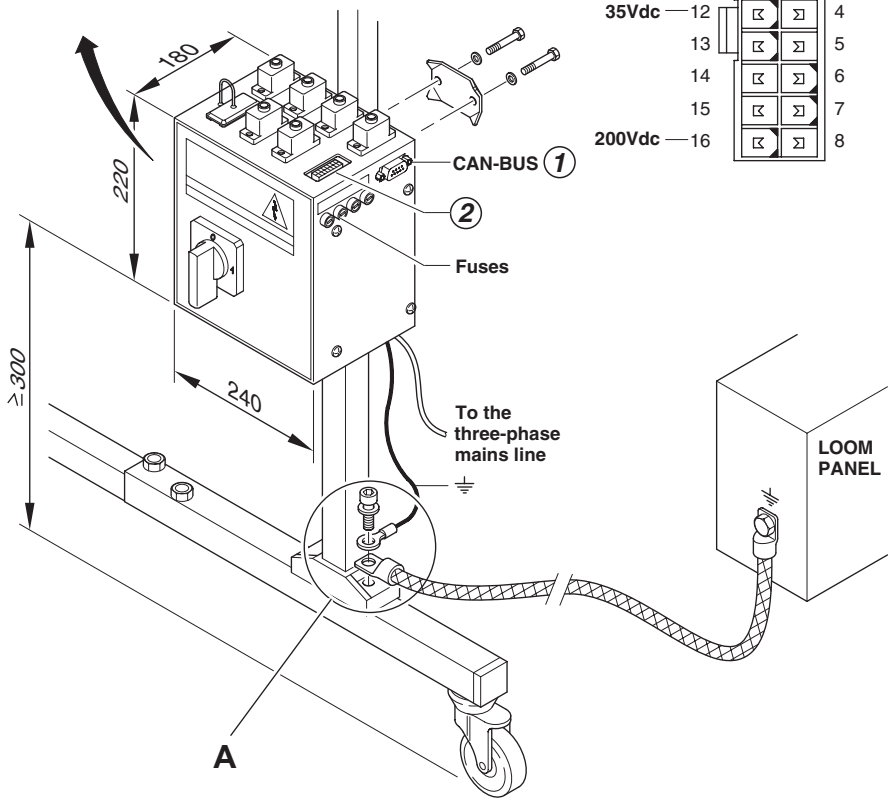
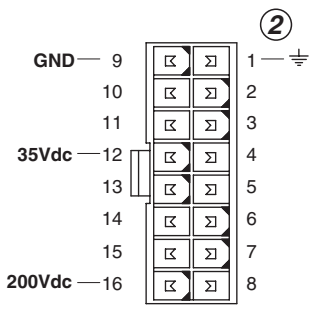
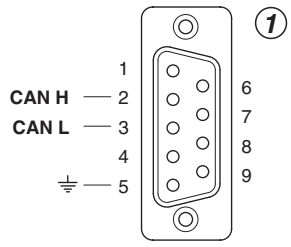
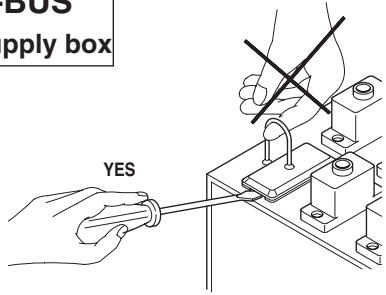



# 3 - INSTALLATION

## 3.2 INSTALLATION OF THE WEFT PRE-MEASURING WINDER

**N.B.:** *Weft pre-measuring winders that are moved from a warehouse into a warmer weaving mill environment may develop condensation due to the temperature differences. Please wait until they are completely dry before connecting them up. Failure to do so may damage the electronic components.*

- 1) Fix the weft pre-measuring winder to its stand using the clamp provided ( $\varnothing 25$ ;  $\varnothing 30$ ;  $\varnothing 32$ ).

**N.B.:** *Make sure that the stand used to hold the weft pre-measuring winder is connected to the earth system.*

- 2) Position the weft pre-measuring winder so that the weft is as straight and as level as possible. Try to avoid bends in the yarn along its way.
- 3) If necessary, fit the weft brake in at the weft pre-measuring winder input if not already fitted on the creel.

- 4) Connect the weft pre-measuring winder to the pneumatic circuit (only where pneumatic threading is provided).

- 5) Switch off the power supply box by switching the 0 - 1 switch onto '0'.

*This is necessary so as not to cause any damage to the weft pre-measuring winder electronics.*

- 6) Switch the weft pre-measuring winder off by switching its 0 - 1 switch onto '0'.

- 7) Connect the weft pre-measuring winder **cable to the power supply box socket marked with the same number as that marked on the loom nozzle fed by said weft pre-measuring winder.**

- 8) Power up the power supply box by switching its 0 - 1 switch to 1.

The green led on the pre-measuring device's electromagnet/photocell unit will flash briefly and then go off (Reset).

- 9) Connect the loom's CAN BUS communication cable or the serial + signal communication cable up to the DB9 loom signal connector.

- 10) Set the weft pre-measuring winder's operating parameters.

- 11) Adjust the diameter of the winding group as indicated in subsequent paragraph 4.2 herein.

## 4 - COMMISSIONING THE UNIT

### 4.1 INPUT SENSOR

Upon request, an input sensor that features a dual function can be fitted onto the pre-measuring winder:

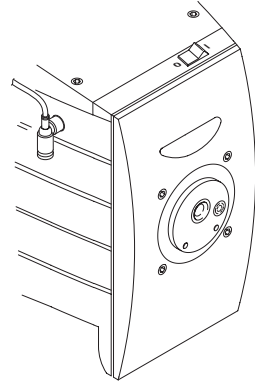

- **Pre-measuring winder with loom stop set function:**

This function stops the pre-measuring winder and the loom if no weft is detected at the winder input (broken weft or end of yarn bobbin).

N.B.: Starting the pre-measuring winder back up by simply switching the 0-1 switch off and then back on again will not be enough. The store coils must be completely removed by keeping the reset key **R** (reset) pressed for longer than 2 seconds. Rethread the winder and restore the winding reserve (as specified in subsequent point 4.5)

**L.G.L. recommends the following procedure in case the "Yarn Brake" alarm is given: When the pre-measuring winder stops, it still carries some store coils on the winder. Carry out a partial (hind) threading cycle, knot the yarn up with the store coils still on the winder and press R to carry out a complete weft yarn removal cycle (as described above). These steps enable: elimination of the knot in the yarn, threading of the loom feeder and nozzles, starting of the pre-measuring winder back up again. Press the S key to restore the winding reserve.**

- **Pre-measuring winder featuring broken wefts exclusion function:**

This function excludes broken wefts by stopping the pre-measuring winder but without stopping the loom. This function is only possible if the loom is set accordingly.

**N.B.: To start the pre-measuring winder back up again, carry out a partial (hind) threading cycle and tie the yarn up to the store coils left on the winder. Then press the S key.**

**The pre-measuring winder will only wind in the number of coils required for reinstatement of standard operation.**

The above two functions will avoid defects in the fabric and - if the exclusion of broken wefts function is set - loom stops due to broken wefts can be avoided as well.

In order for this type of electronic piezoelectric sensor to function properly, it only requires for the weft to run over its sensing element as though said element were a standard weft detector.

## 4 - COMMISSIONING THE UNIT

If the sensor detects that weft yarn is not available, the pre-measuring winder stops operating and gives the “**Bobbin end**” alarm.

**N.B.: If upon giving the alarm the pre-measuring winder is completely empty to start it back up again keep the R key pressed for more than 2 seconds. The green led will stop flashing and the pin is raised. Once this is accomplished, proceed with threading in and restoring the winding reserve.**

The input sensor sensitivity can be adjusted or the input sensor can be disabled by setting the appropriate parameter. To do so, access the pre-measuring winder screen page on the loom terminal screen.

***N.B.: To avoid false stops, make sure that the sensor is always clean so as to enable smooth running of the weft over its sensing element.***

# 4 - COMMISSIONING THE UNIT

## 4.2 HOW TO SET THE LENGTH OF THE WEFT

The number of the coils to be released with each weft insertion and the diameter (from 1 to 8) required for the winding unit may either be established through the loom controls or using the table given below. In the weft pre-measuring winder screen page on the loom terminal screen, enter the required weft-length in cm.

To adjust the diameter of the winding unit, act as follows:

- 1) Make sure that the weft pre-measuring winder is turned off (switch **O** - I on **O**).
- 2) If the funnel kit is present (see accessories), loosen the retaining screw, slide the kit out and block it to the side or remove it so that it will not hinder the adjustment operations (follow the steps given for funnel removal in chapter 7 herein).
- 3) Loosen screw **(6)**; move the electromagnet/photocell unit **(9)** upwards and lock it by tightening the screw back in again.
- 4) Loosen the 6 screws **(7)** that keep the six mobile sectors **(10)** fastened.
- 5) Loosen the 6 screws **(8)** that keep the six fixed sectors **(11)** fastened.
- 6) Position the fixed sectors **(11)** onto the reference lines **(12)** corresponding to the number (from **1** to **8**) matched according to the table below. Tighten the fastening screws **(8)** back in.

NO. OF COILS	POSITION OF THE SECTORS								
	0,5	1,5	2,5	3,5	4,5	5,5	6,5	7,5	8,5
	1	2	3	4	5	6	7	8	
<b>2</b>	66 ... 68	69 ... 71	72 ... 74	75 ... 76	77 ... 79	80 ... 81	82 ... 84	85 ... 88	
<b>3</b>	100 ... 103	104 ... 106	107 ... 110	111 ... 114	115 ... 118	119 ... 122	123 ... 125	126 ... 130	
<b>4</b>	133 ... 137	138 ... 142	143 ... 147	148 ... 152	153 ... 157	158 ... 162	163 ... 167	168 ... 173	
<b>5</b>	166 ... 171	172 ... 177	178 ... 184	185 ... 190	191 ... 196	197 ... 203	204 ... 209	210 ... 216	
<b>6</b>	200 ... 205	206 ... 213	214 ... 221	222 ... 228	229 ... 236	237 ... 243	244 ... 251	252 ... 261	
<b>7</b>	233 ... 240	241 ... 248	249 ... 257	258 ... 266	267 ... 275	276 ... 284	285 ... 292	293 ... 304	
<b>8</b>	268 ... 274	274 ... 284	284 ... 294	294 ... 304	304 ... 314	314 ... 324	324 ... 334	334 ... 347	
<b>9</b>	300 ... 308	309 ... 319	320 ... 331	332 ... 342	343 ... 353	354 ... 365	366 ... 376	377 ... 390	
<b>10</b>	332 ... 342	343 ... 355	356 ... 368	369 ... 380	381 ... 393	394 ... 405	406 ... 418	419 ... 434	
<b>11</b>	366 ... 377	377 ... 390	390 ... 404	404 ... 418	418 ... 432	432 ... 446	446 ... 460	460 ... 476	
<b>12</b>	400 ... 411	412 ... 426	427 ... 441	442 ... 456	457 ... 471	472 ... 486	487 ... 501	502 ... 521	

**N.B.:** Should more than one combination be possible, use of the combination with the least number of coils is recommended.

## 4 - COMMISSIONING THE UNIT

- 7) Press pushbutton **(E)** and keeping it pressed, rotate the flywheel until the pushbutton snaps into the flywheel completely.  
Still keeping the pushbutton pressed, keep rotating the flywheel until the flywheel eyelet is lined up with the pushbutton (consult chapter 4.4).
- 8) Adjust the mobile sectors by rotating the flywheel so that the ceramic eyelet is brought into position at the centre of the fixed sector **(11)** being adjusted.
- 9) Fit the appropriate plastic gauge **(14)** onto the fixed sector and push the mobile sector **(10)** against it.  
Lock the mobile sector by fastening in the relative screw **(7)**.
- 10) Adjust the remaining mobile sectors by repeating above steps 8 and 9 over again.
- 11) To adjust the distance between the electromagnet/photocell unit and the fixed sector, position the flywheel so that the ceramic eyelet is brought into position at the centre of the fixed sector located under the electromagnet / photocell unit.

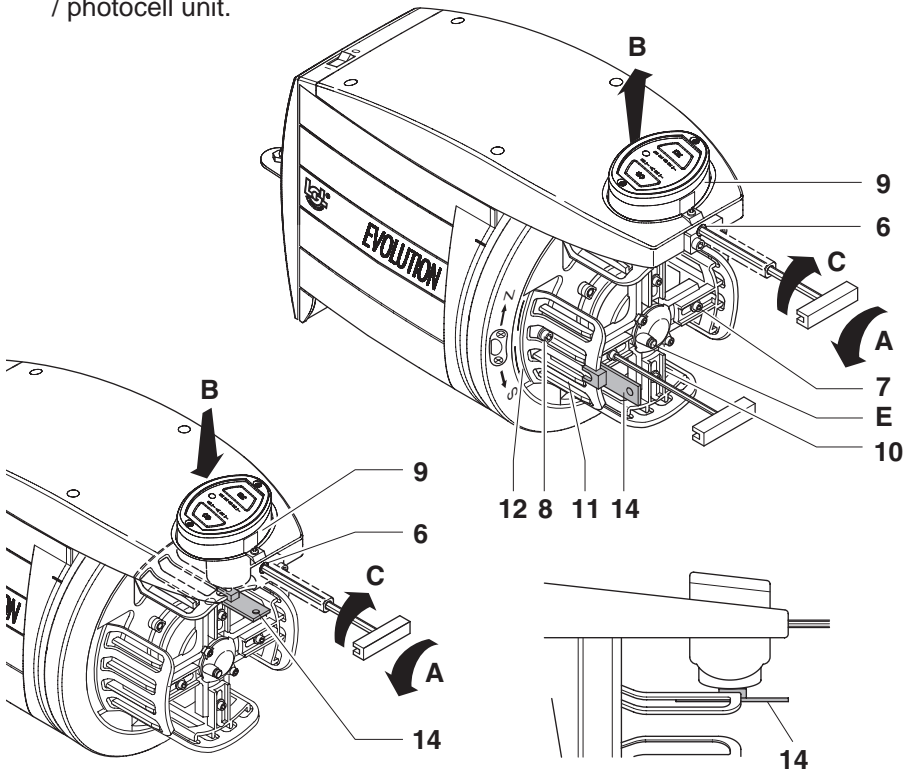

## 4 - COMMISSIONING THE UNIT

- 12) Fit the plastic gauge (14) onto the fixed sector.
- 13) Loosen the screw (6) and lower the electromagnet/photocell unit down until the electromagnet's aluminium body touches up against the gauge. Tighten the screw (6) back in again and remove the gauge.
- 14) Load in the winding reserve as described in the subsequent paragraph herein.
- 15) Start the loom up and make sure that the weft length is set as required for operation.  
If the weft length is in excess, reduce the diameter of the winding unit. If it lacks, increase diameter.

***N.B.: To make minor corrections to the weft length, simply adjust one sector or act on two opposite sectors.***

***Whilst adjusting the diameter, keep the pin raised. To do so press the R key for 2 seconds, then switch the pre-measuring device off. The pin will lower itself down automatically when the device is switched back on.***

### 4.3 THREADING AND WINDING IN THE WINDING RESERVE

- 1) Switch the pre-measuring winder off; (if a Push-Pull device is present, the lever will rise automatically). Where pneumatic threading is not provided, thread the weft pre-measuring winder using the appropriate threading hook. Where partial threading is provided, draw the yarn up close to the weft inlet eyelet and press the **P** pushbutton (check diagram on page 56).

If a tubular funnel is present, thread the yarn in through the funnel by hand. Draw the yarn up to the Push-Pull brake inlet and proceed with final threading by pressing the appropriate **F** pushbutton located on the support bracket.

**N.B.: The brake lever must be kept well above the yarn.**

Thread the weft yarn in through the loom nozzles.

- 2) Switch the weft pre-measuring winder back on by switching the **O - I** switch to **I**.

If there are no faults, the green led on the electromagnet/photocell unit will come on and stay on.

- 3) Press the **S** (start) key; the pre-measuring unit will load in the required winding reserve.

# 4 - COMMISSIONING THE UNIT

## 4.4 ADJUSTING THE COIL SEPARATION

To adjust coil separation, act as follows:

Press pushbutton (E) and keeping it pressed, rotate the flywheel until the pushbutton snaps into the flywheel completely. Still keeping the button pressed, keep rotating the flywheel until the eyelet is lined up with the pushbutton. In this position, coil separation is approx. 0,2 mm both in Z and S directions. Still keeping the pushbutton pressed, rotate the flywheel in the direction of pre-measuring winder's sense of rotation. By doing so, the coil separation pitch can be increased up to max. 2,5 mm.

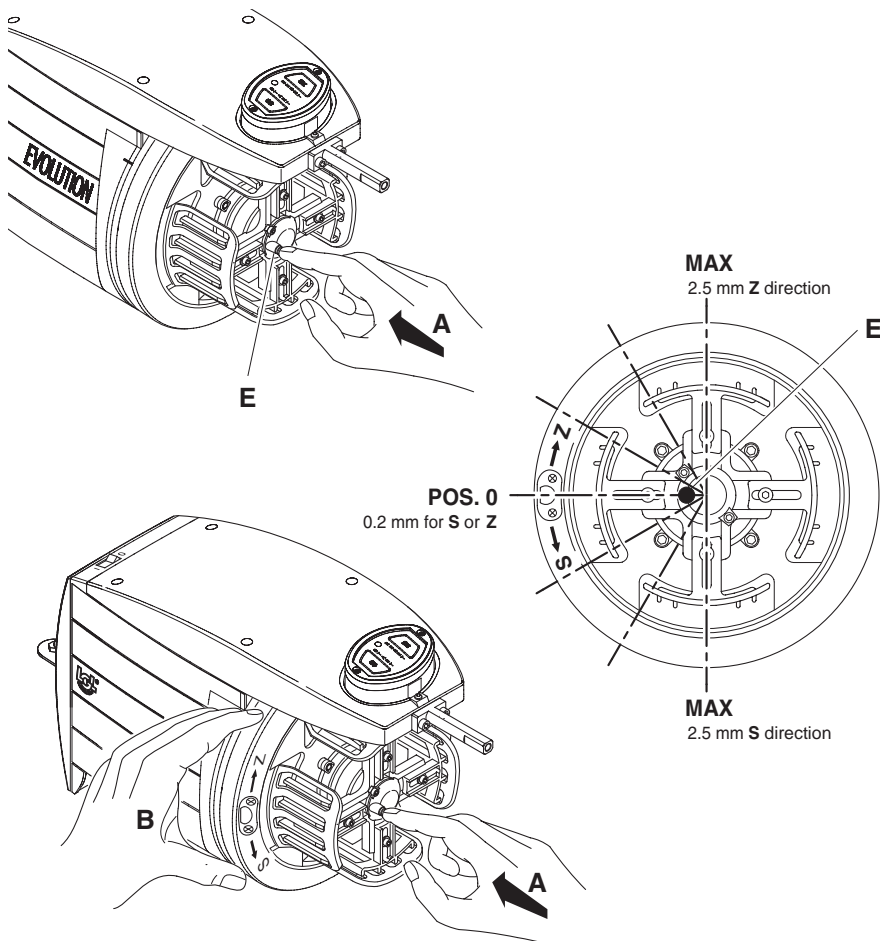

# 4 - COMMISSIONING THE UNIT

## 4.5 RESTORING THE WINDING RESERVE

Due to weft yarn breakage, yarn changes or for a number of other reasons, during standard weaving operations it may be necessary to remove the store coils left on the winding group and wind in a new set of coils.

Proceed as follows:

- 1) Press the **R** (reset) key for more than 2 seconds; the electromagnet pin will rise and keep its raised position.  
Switch the pre-measuring winder off so that the Push-Pull brake lever (if present) also rises automatically.
- 2) Remove the weft yarn still wound on the winding group by hand.  
If the weft on the winding group is still threaded into the loom nozzles, it will be sucked through directly by the nozzles.
- 3) Thread the weft pre-measuring winder using the appropriate threading hook.  
Where partial pneumatic threading is provided, draw the yarn up close to the weft inlet sensor eyelet and press the appropriate (**P**) pushbutton. If a tubular funnel is present, thread the yarn in through the funnel by hand and draw the yarn up to the Push Pull brake inlet. Proceed with final threading by pressing the appropriate (**F**) pushbutton.



***The brake lever must be kept well above the yarn.***

- 4) Thread the weft yarn in through the loom nozzles.
- 5) Switch the weft pre-measuring winder back on. Press the **S** (start) key; the pre-measuring unit will restore the winding reserve.



***When the winder is switched back on again, both the electromagnet pin and the Push Pull lever (if present) will automatically be lowered back down again.***



# 5 - MAINTENANCE AND COMPONENT REPLACEMENT

## 5.1 HOW TO DISMANTLE THE WINDING GROUP

To remove the winding group, proceed as follows:

- 1) Turn the power supply box switch OFF.
- 2) Disconnect the pre-measuring winder's power supply cable from the power supply box socket and wait for about two minutes before continuing, so that the condensers on the electronic boards have time to discharge.
- 3) For pre-measuring winders provided with pneumatic threading: discharge any compressed air by closing the circuit and pressing the **P** threading pushbutton.
- 4) Loosen the screw (6) located on the inside of the pin; raise the electromagnet / photocell unit (9) and lock it by re-tightening the screw back in.

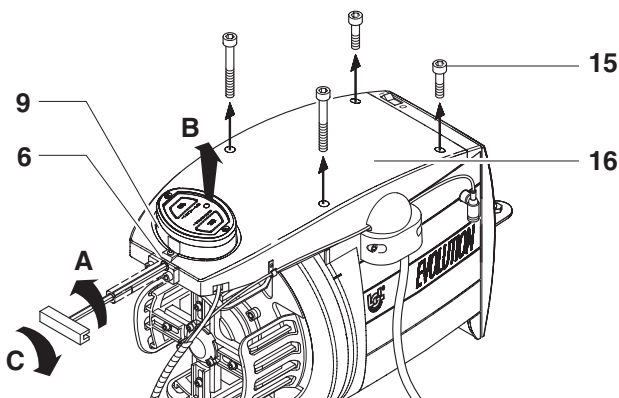

- 5) Remove the four screws (15), lift the top cover panel (16), detach connectors (C1) and (C2) from the electromagnet/photocell unit control board and completely remove the top panel cover. If a funnel is fitted, it will come off together with the top cover. Disconnect the air supply pipe (C8) connected up to the quick-couple connection.

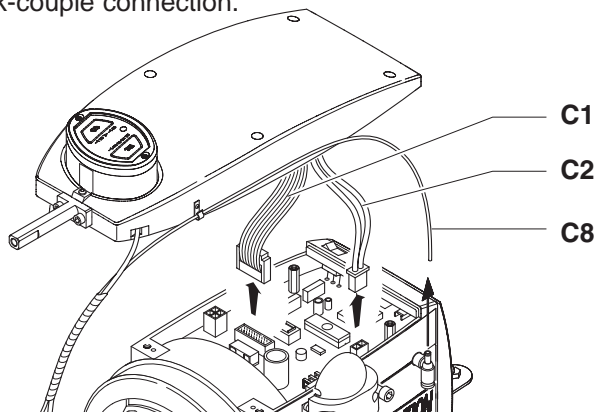

## 5 - MAINTENANCE AND COMPONENT REPLACEMENT

- 6) Remove the four screws (7) and remove all four mobile sectors (10).
- 7) Remove the 2 cover cap screws (20) and remove cap. Remove central screw (21), the washer (22), the bushing (23) and the equaliser ring (24).

**Caution:** when fitting the cross piece back on, make sure that the tooth on the bushing mounted inside the cross piece slots into the appropriate groove on the equaliser ring and that the threaded holes (K) that fix in the adjuster cap are positioned to the upper left and lower right hand sides (as illustrated).

- 8) Remove the 4 screws (25) that fix the bellow-wheel to the sector support; remove the oscillator assembly (26) by pulling it outwards. To replace the bellow-wheel (27), remove the 4 screws (28) locking it to the cross-piece.

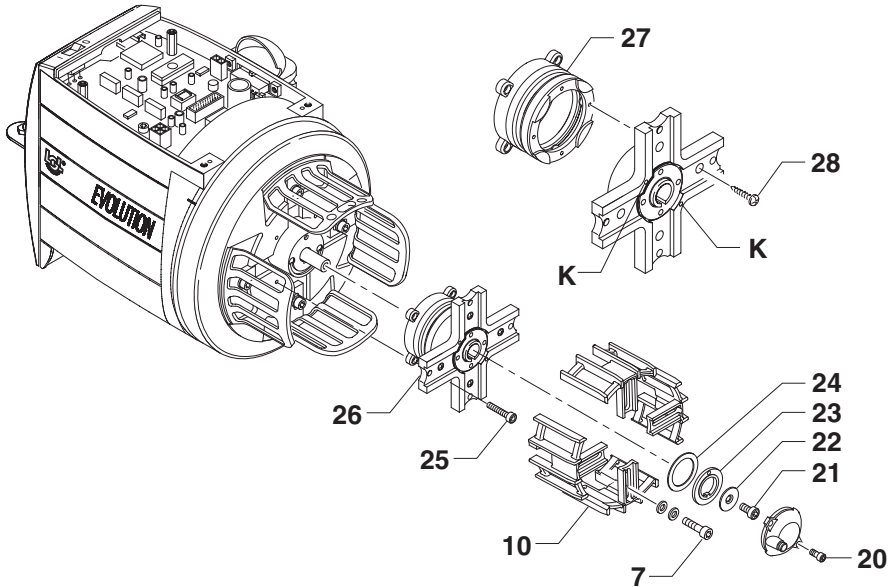

- 9) Slip out balance wheel (29). Using the proper tool (to be ordered), turn out bushing (30).

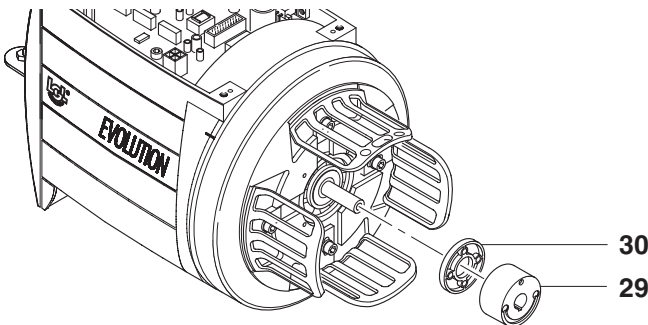

## 5 - MAINTENANCE AND COMPONENT REPLACEMENT

- 10) Remove the winding group (31).

If the winding group is difficult to remove by hand, use the appropriate tool for winding group extraction (to be ordered).

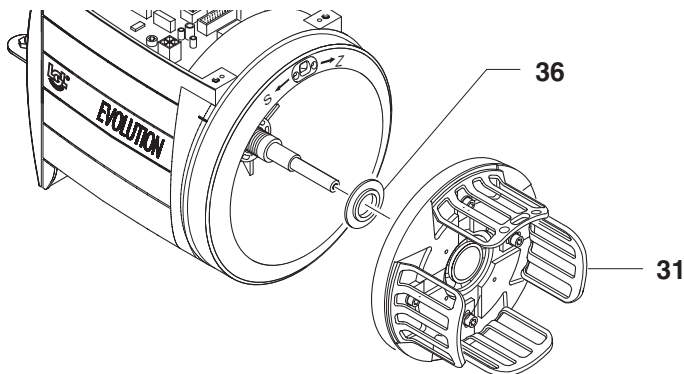

- 11) Slide out the flywheel assembly (32) keeping the ceramic eyelet faced upwards.

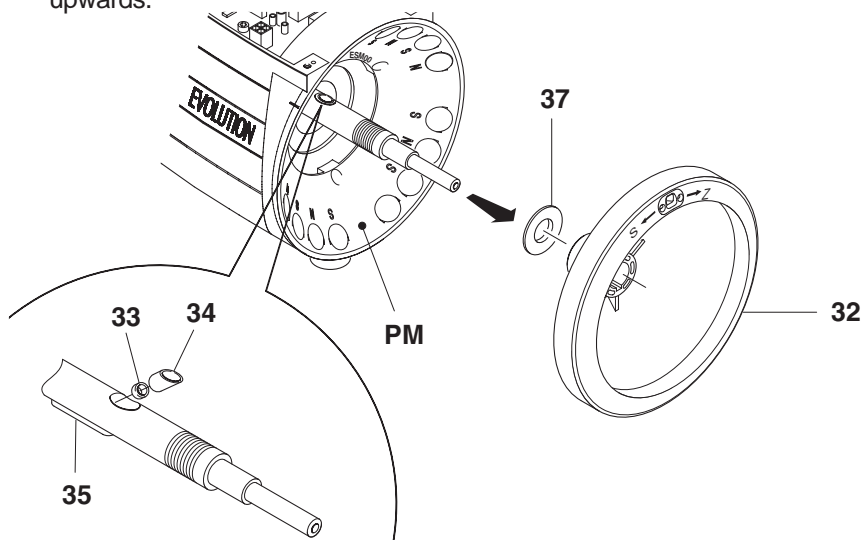

The ceramic eyelet (33) and the thread guide (34) fitted on the shaft can also now be easily replaced.

Caution must be taken with the pin key (35) and with the spacers (36-37) because they are mounted in directions opposite to one another and have varying thickness. If the magnet support (PM) is also removed, it has to be fitted back in by positioning its mounting footholds so that the component item no. printed on said support is located on the upper side.

# 5 - MAINTENANCE AND COMPONENT REPLACEMENT

## 5.2 REPLACING THE INPUT SENSOR

For input sensor replacement act as follows:

- 1) Turn OFF the power supply box switch.
- 2) For pre-measuring winders provided with pneumatic threading: discharge any compressed air by closing the circuit and pressing the **P** threading-pushbutton.
- 3) If fitted, remove the brake on the weft pre-measuring winder input.
- 4) Turn out the 4 screws (**38**) and remove the cover (**39**).
- 5) Disconnect the input sensor connector (**C3**).
- 6) Remove the two screws (**40**) and remove the sensor support plate (**41**).
- 7) If the weft pre-measuring winder is fitted with pneumatic threading, detach tube (**42**).
- 8) Replace sensor (**43**).

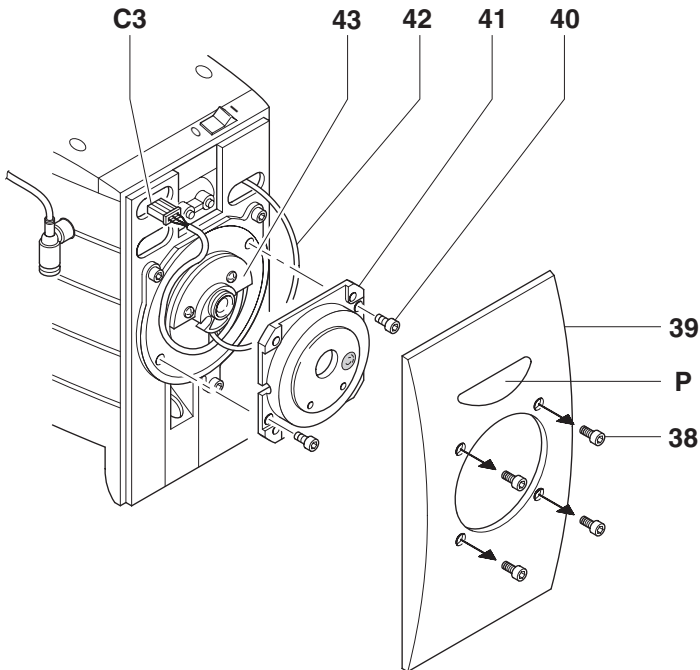

**NOTE:** Take care not to crush the sensor cable and the pneumatic circuit tubes when reassembling the sensor support plate (37) and cover (35) back on.

# 5 - MAINTENANCE AND COMPONENT REPLACEMENT

## 5.3 REPLACING THE L.G.L. 103 MAIN ELECTRONIC CONTROL BOARD

To replace the main electronic control board, proceed as follows:

- 1) Turn the power supply box switch OFF.
- 2) Remove the two screws (44) and disconnect the power supply cable connector.
- 3) For pre-measuring winders provided with pneumatic threading: discharge all compressed air by closing the circuit and pressing the **P** threading pushbutton.
- 4) Loosen screw (6); raise the electromagnet/photocell unit (9) and lock it by re-tightening the screw back in.  
(This step is not necessary if the diameter of the winding group remains unaltered).

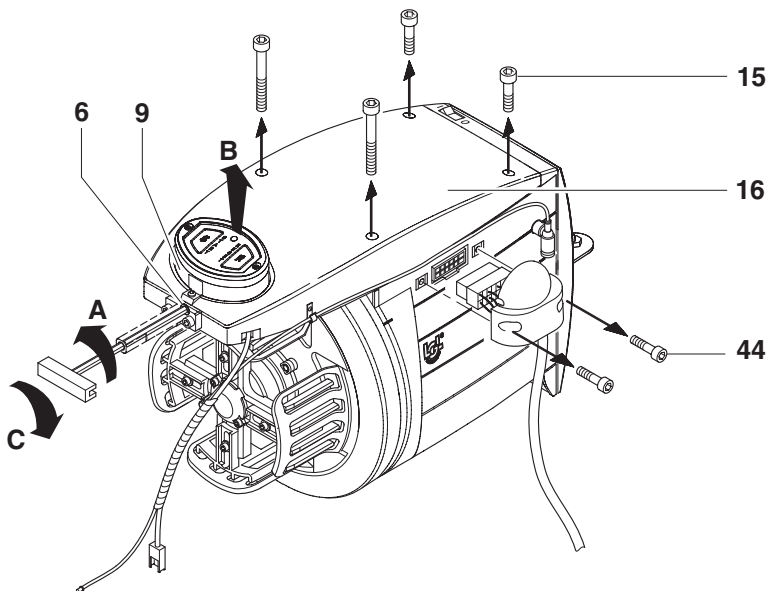

- 5) Remove the four screws (15), lift the top cover panel (16), detach connectors (C1) and (C2) from the electromagnet/photocell unit control board, disconnect the air supply pipe (C8) and completely remove the top panel cover.  
If a funnel is fitted, it will come off together with the top panel cover.

## 5 - MAINTENANCE AND COMPONENT REPLACEMENT

- 6) If fitted, detach the input sensor connector (**C3**) and the motor connector (**C4**).

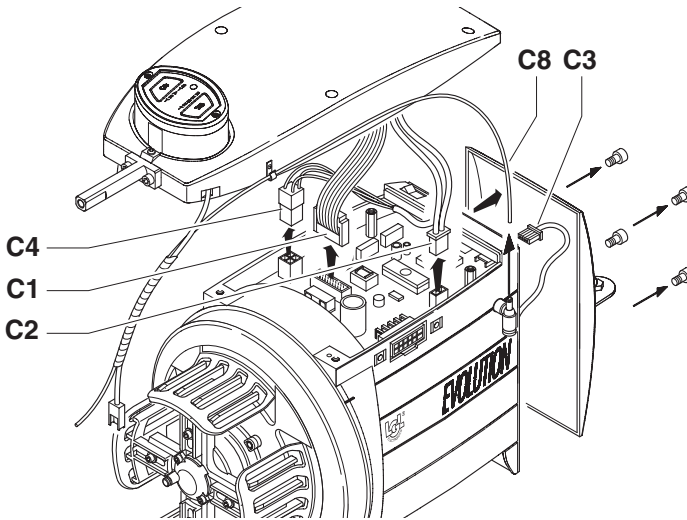

- 7) Unscrew both spacers (**45** and **46**), remove screw (**47**) and remove the main electronic control board.

**N.B.:** When fitting the new control board in, it is very important that the relative spacers and the screw are tightened in thoroughly so that the board's aluminium bracket is firmly fitted against the pre-measuring winder's aluminium housing. We also recommend placing some thermo-conductive paste along the surface of the bracket that comes into direct contact with the pre-measuring winder housing.

**Caution:** Spacer **46** is longer; screw it back into its original position.

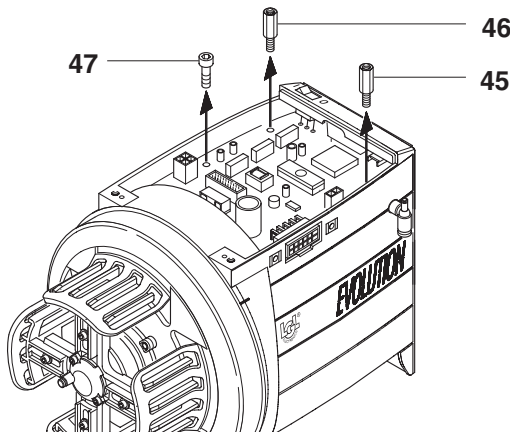

# 5 - MAINTENANCE AND COMPONENT REPLACEMENT

## 5.4 REPLACING THE ELECTROMAGNET/PHOTOCELL UNIT AND RELATIVE L.G.L. 114 CONTROL BOARD.

In case of failure by either the L.G.L. 114 control board or due to the electromagnet inside the electromagnet/photocell unit, both the L.G.L. 114 board and the electromagnet/photocell unit need to be replaced.

Should the failure be only by the photocell, only the photocell needs replacing.

To replace control board L.G.L. 114 together with the electromagnet/photocell unit proceed as follows:

- 1) Turn **OFF** the power supply box switch.
- 2) Remove the two screws (**44**) and detach the power supply cable connector.
- 3) For pre-measuring winders provided with pneumatic threading: discharge any compressed air by closing the circuit and pressing the **P** threading-pushbutton.
- 4) Loosen screw (**6**); raise the electromagnet/photocell unit (**9**) and lock it by re-tightening the screw.

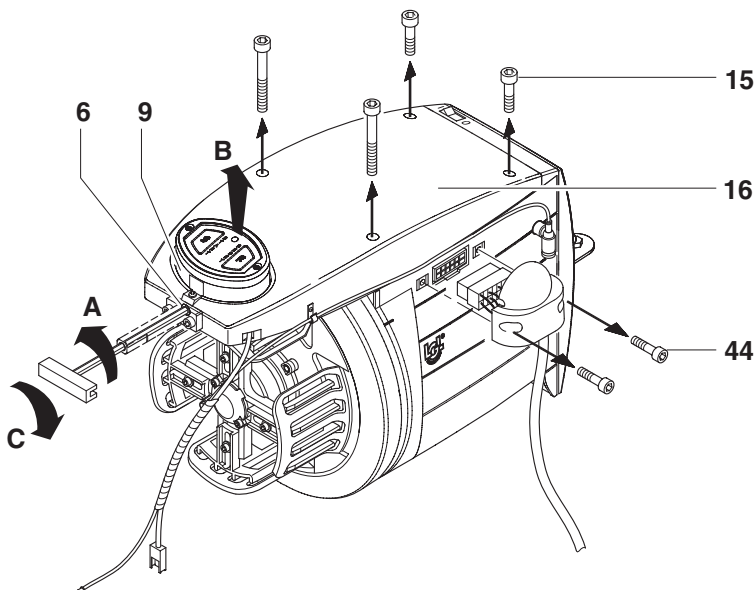

## 5 - MAINTENANCE AND COMPONENT REPLACEMENT

- 5) Remove the four screws (15), lift the top cover panel (16) by pulling it slightly forward, detach connectors (C1) and (C2) disconnect the air supply pipe (C8) and remove the top panel cover.

If a funnel is fitted, it will come off together with the top panel cover.

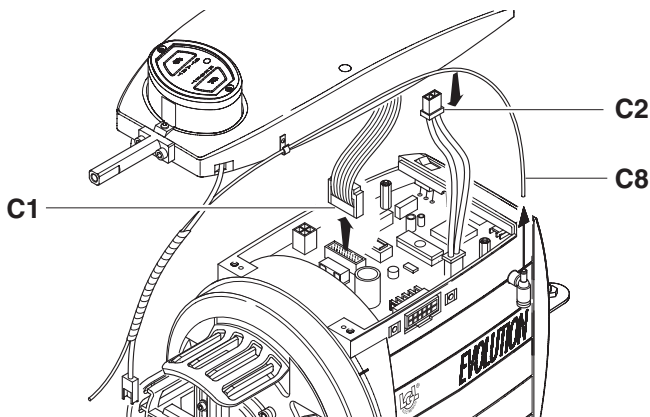

- 6) Remove the four screws (48) and remove the cover plate (49).
- 7) Remove the screw (50); carefully raise the L.G.L. 114 board (51), tilting it so that the electromagnet (C5) and photocell (C6) connectors can be detached.

Remove the board.

To make it easier to remove connectors (C5) and (C6) loosen screw (6) and move the electromagnet/photocell unit into a position where the relative cables are longest.

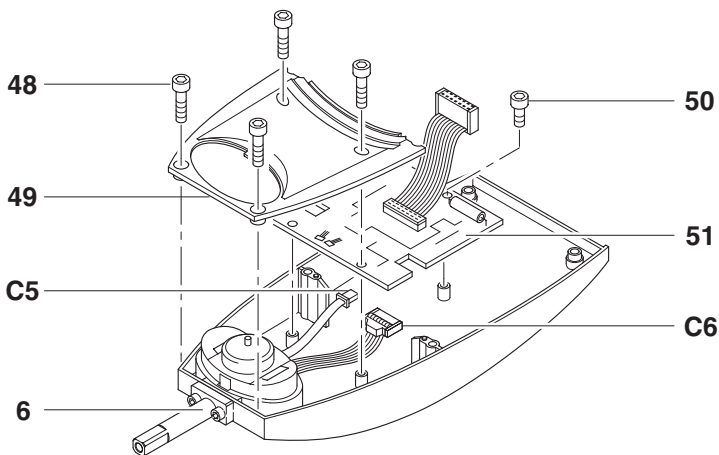



# 5 - MAINTENANCE AND COMPONENT REPLACEMENT

- 8) Loosen lock screw (6) and slide the electromagnet/photocell unit upwards. Do so very carefully, so as not to damage the flexible wiring leading to both the electromagnet and photocell.
- 9) Fit in the new electromagnet/photocell unit and the relevant control board.

## 5.5 REPLACING THE PHOTOCELL AND RELATIVE L.G.L. 112 BOARD

For replacement of the photocell and relevant L.G.L. 112 control board, proceed as follows:

- 1) Remove the two screws (52) and very carefully raise the keyboard.
- 2) Detach connector (C7) connecting the photocell board to the keyboard. Detach connector (C10) connecting the photocell board to the L.G.L. 114 board.
- 3) Remove the two screws (53) and extract the photocell together with the relevant L.G.L. 112 board (54).
- 4) Replace the photocell together with the relative L.G.L. 112 board.

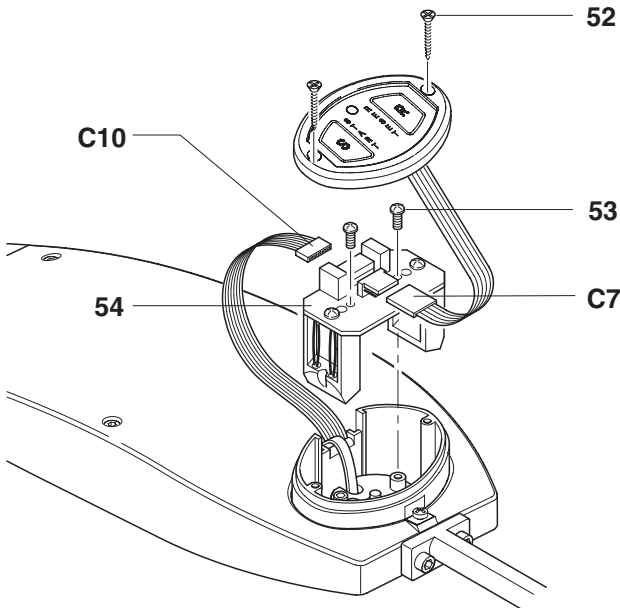

# 6 - ELECTRICAL SPECIFICATIONS

## 6.1 POWER SUPPLY BOX FUSES:

35 V DC fuse protection 5x20 4 A - delayed.

140 V AC three-phase fuse protection 5x20 4 A - delayed.

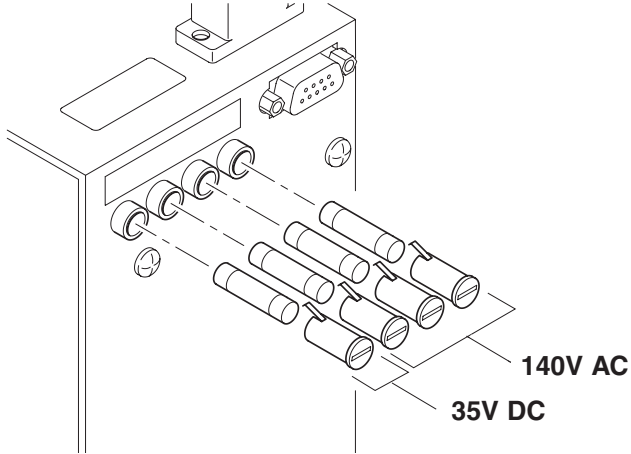

## 6.2 PRE-MEASURING WINDER MAIN ELECTRONIC CONTROL BOARD FUSE:

6.3 A fuse - delayed.

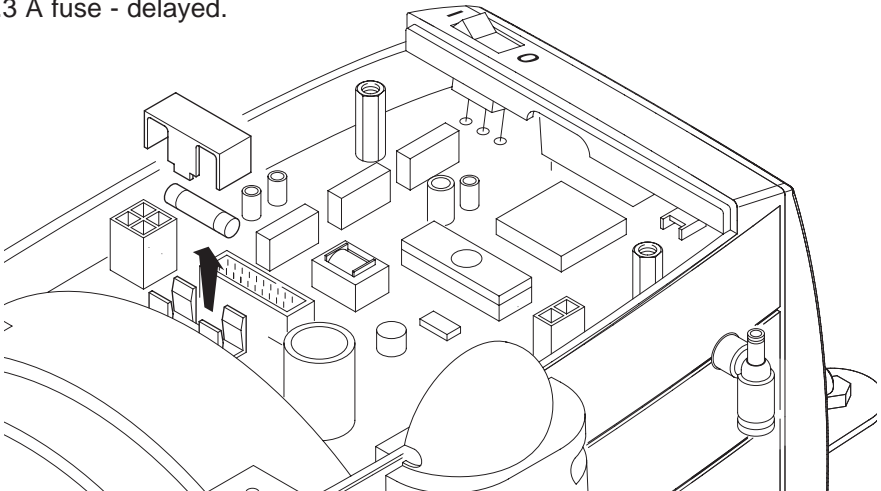

# 7 - PUSH-PULL

## 7.1 DESCRIPTION

The Push-Pull unit is an electronic weft brake that can be applied onto the weft outlet of the pre-measuring winder. Relative operating parameters are managed directly via loom controls (if access to the pre-measuring unit management software is enabled).

**All pre-measuring winder control boards are pre-set for Push-Pull management.**

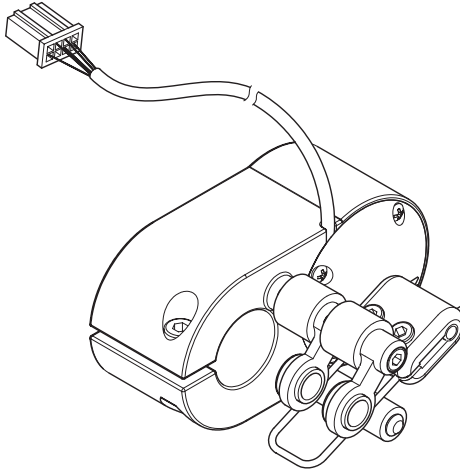

## 7.2 FUNCTIONS

The Push-Pull unit allows for weft speed reduction before it is stopped by the electromagnet unit, thereby decreasing the tension peaks produced by the yarn stops and allowing for smoother weft insertion throughout the loom shed (ABS function). Broken and “slack” wefts in the fabric (loops and snarls) are considerably reduced. The Push-Pull also has the ability of acting as a weft pull-back device (Pull-Back function) that pulls the weft yarns left streaming out of the nozzle after cutting back in, thereby preventing said weft ends from interfering with other weft yarns about to be inserted.

## 7.3 RECOMMENDED USE

The Push-Pull device is supplied separately.

L.G.L. Electronics recommends use of this device for weaving fabrics with weft yarns likely to provide the inconveniences specified in the above Push-Pull functions.

# 7 - PUSH-PULL

## 7.4 ASSEMBLY

For assembly of the Push-Pull unit onto a weft pre-measuring winder, either a funnel kit or a Push-Pull support is required.

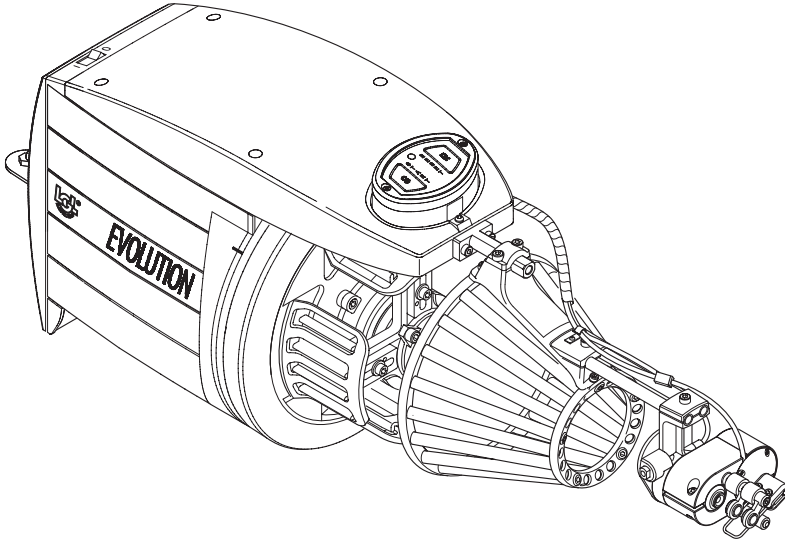

### Assembly:

- a) Fasten the funnel to the pin (55) using screw (56) supplied with the funnel kit.
- b) Fix the Push-Pull unit onto the funnel end using the screw (57) that is located in the weft brake body.
- c) Connect the male connector (58) up with the appropriate female connector (59) on the pre-measuring winder cable.
- d) Hook the air supply pipe (60) up, using the quick coupling.
- e) To be able to rotate the funnel kit so that the centre hub may be adjusted, follow the procedure detailed as follows.

# 7 - PUSH-PULL

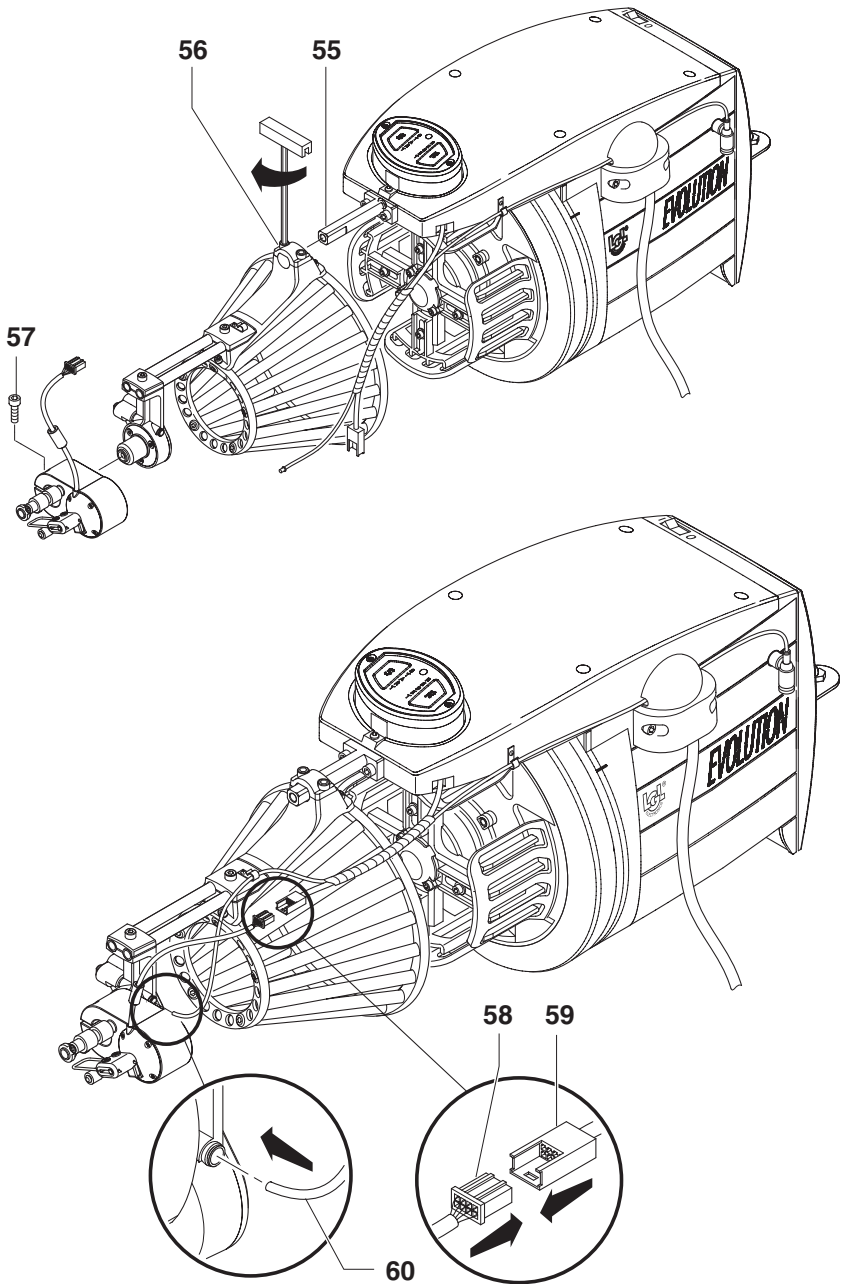

## 7 - PUSH-PULL

Funnel rotation:

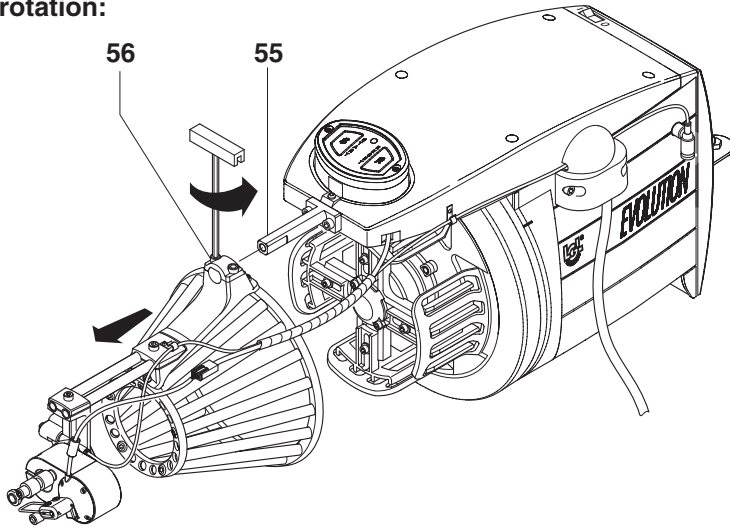

a) Loosen screw (56) and slide the funnel out (without detaching the connectors).

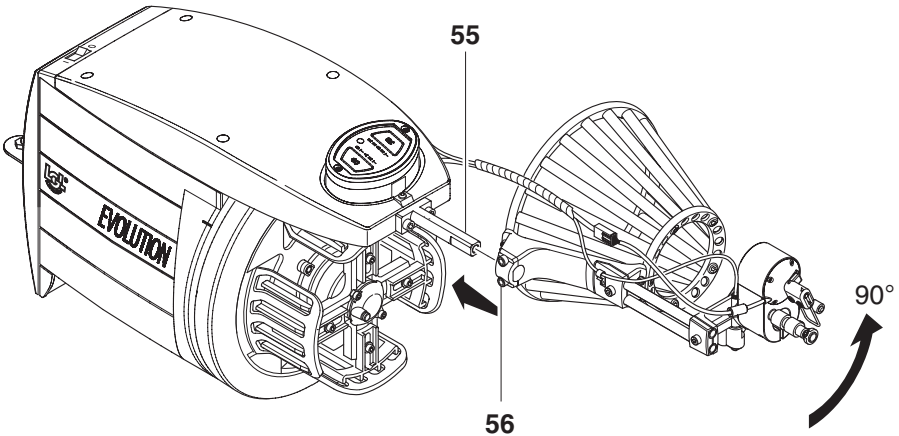

b) Rotate the funnel at 90° outwards and slip it onto the pin (55).

c) Carry out the adjustments and once completed, reposition the funnel back into its initial position. Fix it in with the appropriate screw (56).

### 7.5 START-UP

To set the Push-Pull parameters directly from the loom, if pre-set, please refer to the table in the Loom Terminal: "L.G.L. Pre-winder parameters".

### 7.6 HOW TO REPLACE OR REPOSITION THE BRAKE

Should it be necessary to replace the brake with a new one or if software updating of the pre-measuring winder is required, the following steps for re-acquisition of the brake positions by the pre-measuring winder must be carried out:

- completely remove all yarn from the brake
- turn OFF the pre-measuring winder by turning the switch onto **0**.
- press the “**R**” and “**S**” pushbuttons simultaneously for longer than 2 sec.

Now the brake will move automatically upwards - downwards and vice versa in a continuous manner.

When the brake has completely lowered itself all the way down, switch the pre-measuring winder back on (switch on **1**).

The brake will position itself at its highest end for about 2 sec, then at its lowest end for about 2 sec. Here it will settle itself slightly under the bushings.

At this point the pre-measuring winder has acquired both the brake's max. highest and max. lowest positions.

If the brake will NOT go through the above motions when the pre-measuring winder is turned back on, repeat the whole sequence starting right from the beginning again.

## 9 - TROUBLE SHOOTING

FAULTS	REMEDIES
<p><b>When pressing the S key the pre-measuring winder will not wind the yarn onto the winder and the led starts flashing rapidly.</b></p>	<ul style="list-style-type: none"> <li>- Check that the flywheel rotates freely.</li> <li>- Check the 8A fuses in the power supply box.</li> <li>- Check the 6,3 A fuse in the pre-measuring winder's main control board.</li> <li>- If the problem persists, replace the L.G.L. 103 main control board.</li> </ul>
<p><b>The led flashes slowly and the pre-measuring winder will not function, even when it is switched off and then switched back on again.</b></p>	<ul style="list-style-type: none"> <li>- Check that the pre-measuring winder is not signalling that there is no weft at the winder input by pressing the R key for more than 2 seconds.</li> <li>- If the pre-measuring winder will still not start up, turn the switch on the power supply box to OFF. This will reset the winder completely.</li> <li>- If the fault persists, replace the main control board.</li> </ul>
<p><b>The led flashes slowly, the pre-measuring winder will not wind in the store coils.</b></p>	<ul style="list-style-type: none"> <li>- The voltage in the control board may have sunk to less than 16V DC.</li> </ul> <p>Check that the power supply voltages in the three-phase transformer inlet in the power supply box are correct.</p>
<p><b>The led flashes rapidly during operations. The loom alarm signals that the winder photocell is contaminated.</b></p>	<ul style="list-style-type: none"> <li>- The signal received by the coil-count photocell could be wrong. Please check.</li> <li>- Inspect that the distance between the electromagnet/photocell unit's aluminium housing and the fixed sector located beneath it is correct.</li> </ul>





## 9 - TROUBLE SHOOTING

FAULTS	REMEDIES
<p><b>The led flashes rapidly during operations.</b>  <b>The loom alarm signals that the winder photocell is contaminated.</b></p>	<p>Please adjust using the appropriate gauge supplied with the winder.</p> <ul style="list-style-type: none"> <li>- Clean the mirror and the photocell using a cloth moistened with water.</li> <li>- If, after having carried out all the above the fault still persists, replace the photocell and the L.G.L. 112 board located inside the electromagnet/photocell unit.</li> </ul>
<p><b>The led flashes rapidly after loom has stopped due to weft not correctly inserted.</b></p>	<ul style="list-style-type: none"> <li>- The weft pre-measuring winder alarm signal flashes to show that the last coil release was not accomplished correctly.                      The led will stop flashing automatically right after next correct insertion.</li> </ul>
<p><b>The pre-measuring winder stops the loom with the bobbin-end alarm right after the loom has been started up and even if the yarn is actually present at the inlet.</b></p>	<ul style="list-style-type: none"> <li>- Inspect input sensor function by checking to see that the green led lights up and stays on when the yarn runs over the sensor.</li> <li>- Check that there is no dust or lint residues on the inside of the input sensor. If required, remove the sensor and clean it.                      If a very fine yarn is being used in production, we suggest setting of the <b>"Inlet. detect. sensit."</b> parameters.</li> </ul>
<p><b>The winder will not start up.</b></p>	<ul style="list-style-type: none"> <li>- Check the 35V DC 4 A delayed fuse, as well as checking the main power supply.</li> </ul>



## 9 - TROUBLE SHOOTING

FAULTS	REMEDIES
<p><b>One of the pre-measuring winders or a set of pre-measuring winders will not dialogue with the loom.</b></p>	<ul style="list-style-type: none"> <li>- Check the connection on the relative communication cable.</li> <li>- Check the pre-measuring winder's exact connection position within the power supply box. The numbered position must correspond exactly with the nozzle related to the weft pre-measuring winder.</li> <li>- Check by reading off the eeprom version of the pre-measuring winders in the Socos, whether it is only one winder that is not communicating. If it is actually only one winder that is not communicating the eeprom version, replace the pre-measuring winder's L.G.L. 103 control board.</li> </ul>
<p><b>The Push Pull brake will not work</b>  <i>Caution: if the pre-measuring winder is powered up without the Push-Pull brake being connected in, the control board will disable the brake control function. To be able to reset brake functioning, disconnect power mains, connect the brake up and then restore power connection.</i>  <b><i>In case brake replacement is required the procedure described in chapter 7.6 must be carried out exactly.</i></b></p>	<ul style="list-style-type: none"> <li>- Check relative parameters set in the Socos.</li> <li>- If possible, replace the brake with one that will surely work; if this still doesn't solve the problem, replace the L.G.L. 114 control board located under the weft pre-measuring winder's cover panel. (Check relative instructions).</li> </ul>
<p><b>The electro-magnet unit will not release the coils, the pin will not rise even if the R key is pressed.</b></p>	<ul style="list-style-type: none"> <li>- Replace the electromagnet unit. If the fault persists, replace the L.G.L. 114 control board located under the cover panel. (Check relative instructions).</li> </ul>

## STRIPPING AND SCRAPPING

If stripping and scrapping of the machine is required, relative rating plates and all related documents must be destroyed or cancelled.

If the machine is to be scrapped by third parties, only authorised centres are to be used for any waste recovery or disposal of the ensuing materials.

If the machine is scrapped directly by the user, it is important that the materials are split according to their category and the disposed of separately through specialised centres.

All metal parts, the electrical motor, rubber parts and all the parts produced with synthetic materials must be separated for recycling. Scrapping must at all times be carried out in full conformity with prevailing laws in the country of use wherefore any liability for non compliance with any local requirement lies solely with the last proprietor of the machine and/or any appointed nominee.

**L.G.L. Electronics** will not be held liable for any damage or injury whatsoever arising from reuse of any one of the machine components for operations or assemblies that do not in any way conform to the original use the machine was intended for.