



Rev. 1
02/26

ECO^{POWER} 2

SPARE PARTS

EXPLODED VIEW - TAB. 0

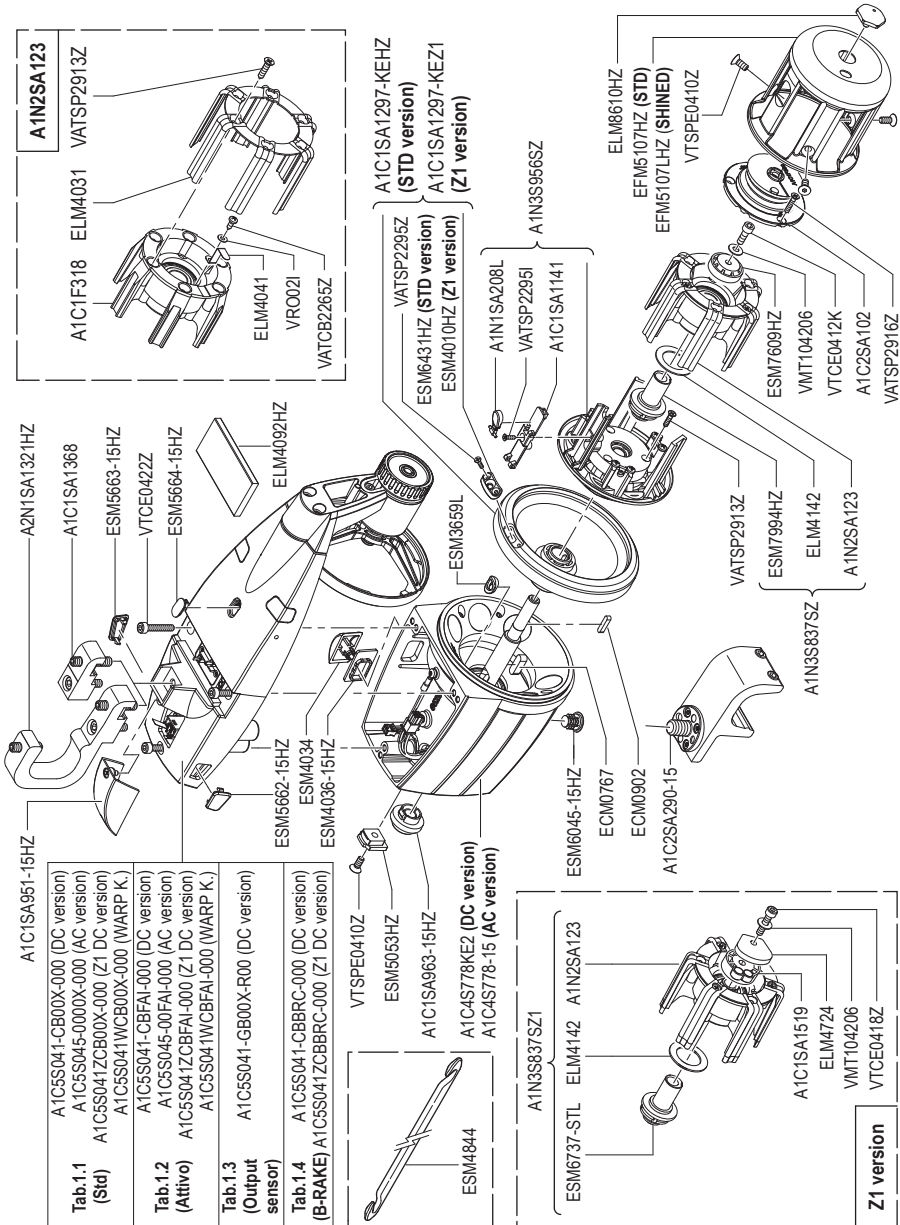

EXPLODED VIEW - TAB. 1.1

A1C55041-CB00X-000 (DC version)
A1C55045-0000X-000 (AC version)
A1C55041ZCB00X-000 (Z1 DC version)
A1C55041WCB00X-000 (WARP KNITTING)

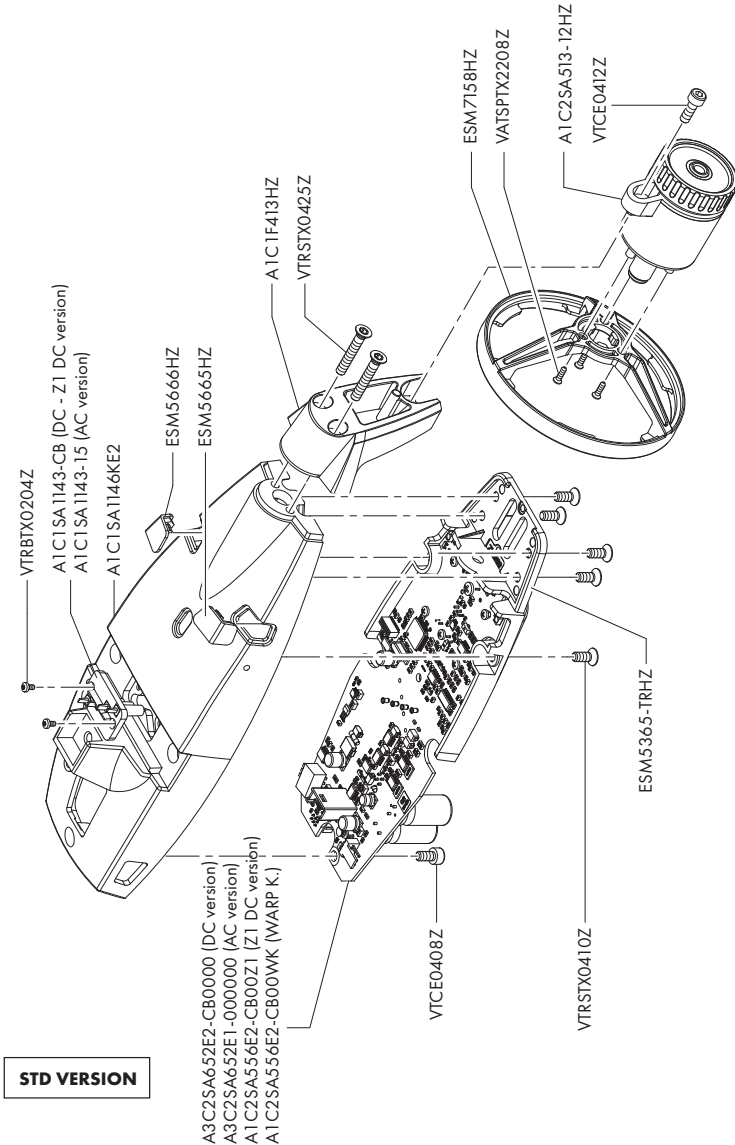

EXPLODED VIEW - TAB. 1.2

ATTIVO VERSION

A1C55041-CBFAI-000 (DC version)
A1C55045-00FAI-000 (AC version)
A1C55041ZCBFAI-000 (Z1 DC version)
A1C55041WCBFAI-000 (WARP KNITTING)

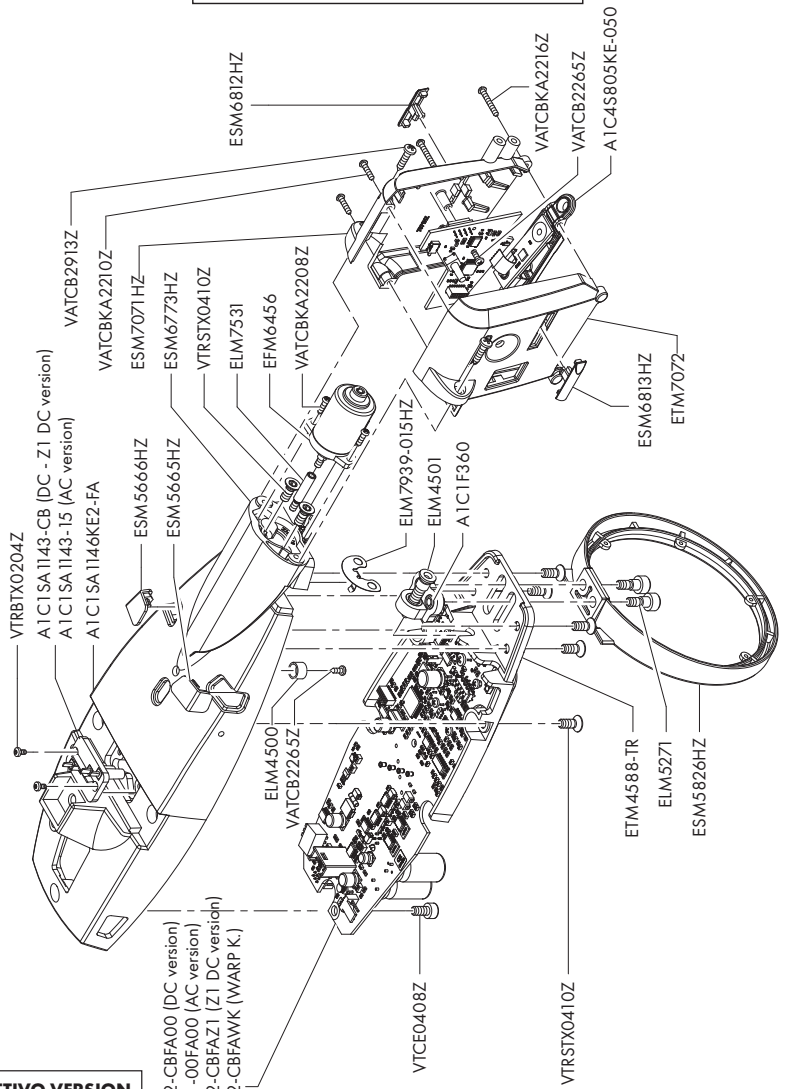

A1C2SA556E2-CBFA00 (DC version)
 A3C2SA652E1-00FA00 (AC version)
 A1C2SA556E2-CBFAZ1 (Z1 DC version)
 A1C2SA556E2-CBFAWK (WARP K.)

EXPLODED VIEW - TAB. 1.3

A1C5S041-GB00X-R00 (DC version)

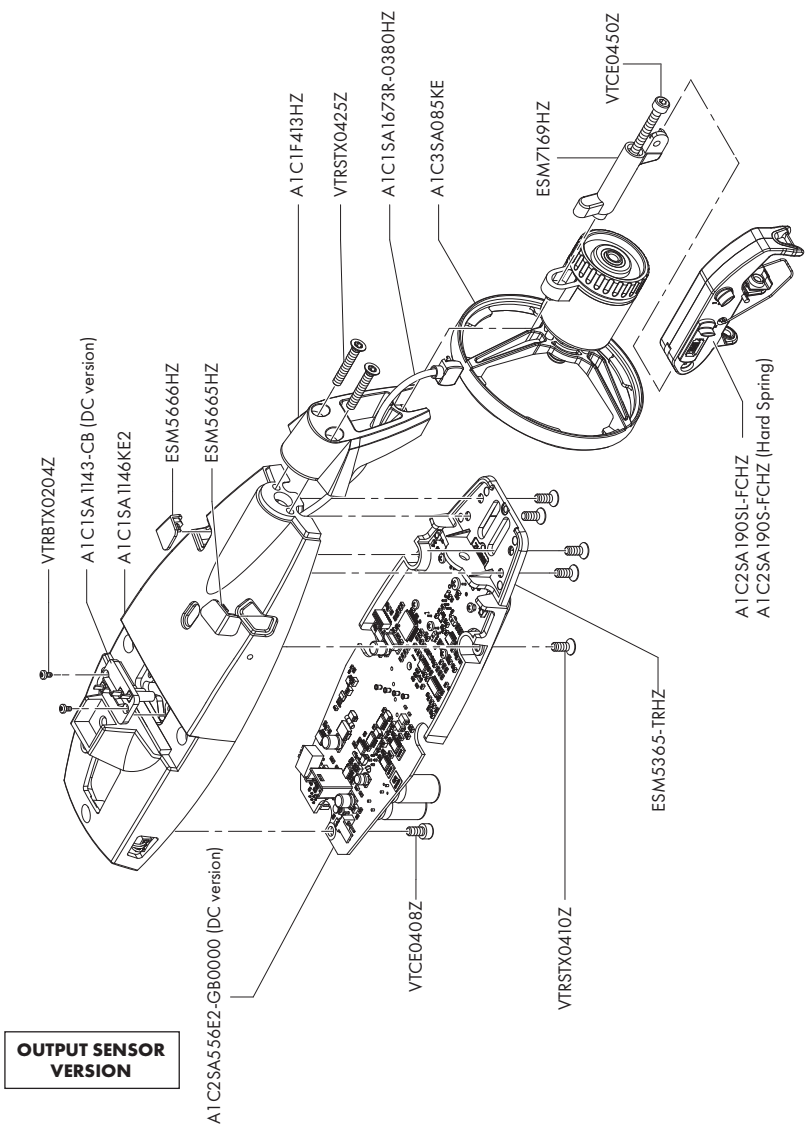

EXPLODED VIEW - TAB. 1.4

A1C55041-CBBRC-000 (DC version)
A1C55041ZCBBRC-000 (Z1 DC version)

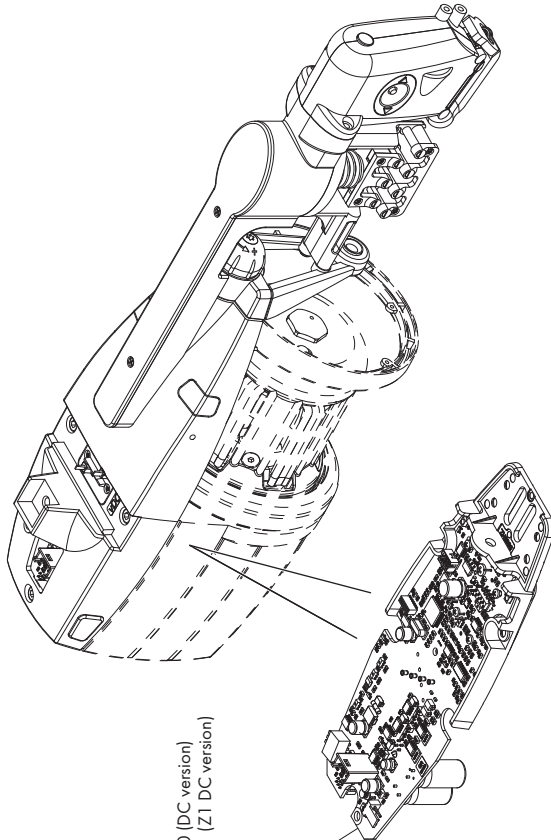

B-RAKE
VERSION

A1C2SA499E2-CBFA00 (DC version)
A1C2SA499E2-CBFAZ1 (Z1 DC version)

EXPLODED VIEW - TAB. 2.1

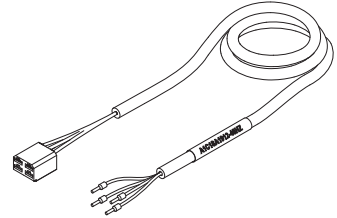
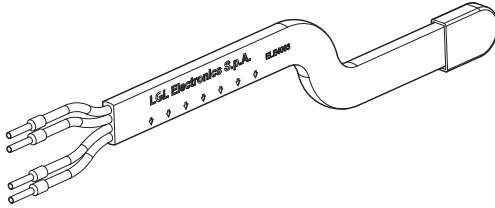

CODICE	L=XXX (mm)
A1N1SA572-2000	2000
A1N1SA572-5000	5000
A1N1SA572-6000	6000
A1N1SA572-8000	8000
A1N1SA572-10000	10000
A1N1SA572-11000	11000

A1C1SA1912-XXXX

CONNECTION CABLE

SOCKS

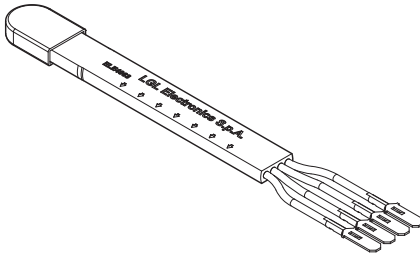
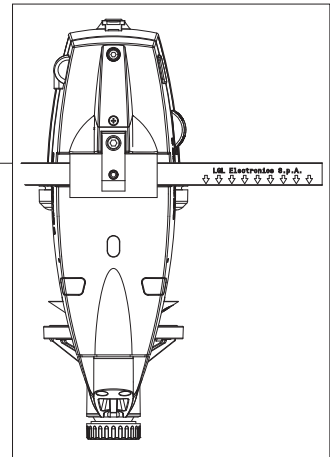

CODICE	L=XXX (mm)
A1C1SA1000-1500	1500
A1C1SA1000-3000	3000
A1C1SA1000-3300	3300
A1C1SA1000-5000	5000
A1C1SA1000-6000	6000
A1C1SA1000-8000	8000
A1C1SA1000-11MT	11000
A1C1SA1000-12MT	12000

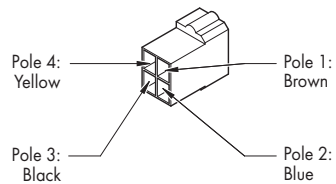

LARGE DIAMETER AC

EXPLODED VIEW - TAB. 2.2

CODE (LEFT)	L=XXX (mm)
A1C2SA391-015L	1500
A1C2SA391-020L	2000
A1C2SA391-030L	3000
A1C2SA391-040L	4000
A1C2SA391-050L	5000
A1C2SA391-060L	6000
A1C2SA391-070L	7000
A1C2SA391-080L	8000
A1C2SA391-090L	9000
A1C2SA391-100L	10000
A1C2SA391-110L	11000
A1C2SA391-120L	12000
A1C2SA391-140L	14000

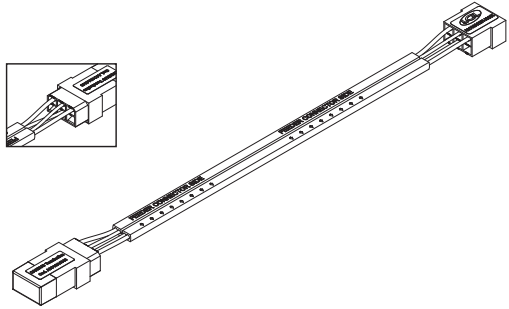

LARGE DIAMETER DC - LEFT

EXTENSION CABLE: A1C1SA1251-XXXX

CODE (RIGHT)	L=XXX (mm)
A1C2SA391-015R	1500
A1C2SA391-020R	2000
A1C2SA391-030R	3000
A1C2SA391-040R	4000
A1C2SA391-050R	5000
A1C2SA391-060R	6000
A1C2SA391-070R	7000
A1C2SA391-080R	8000
A1C2SA391-090R	9000
A1C2SA391-100R	10000
A1C2SA391-110R	11000
A1C2SA391-120R	12000
A1C2SA391-140R	14000

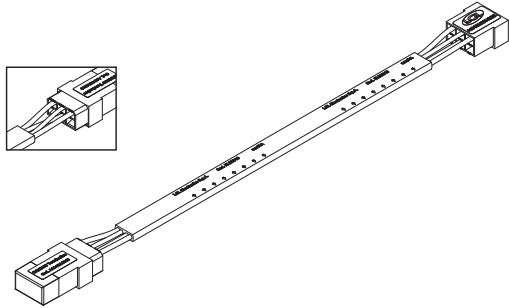

LARGE DIAMETER DC - RIGHT

EXTENSION CABLE: A1C1SA1218-XXXX

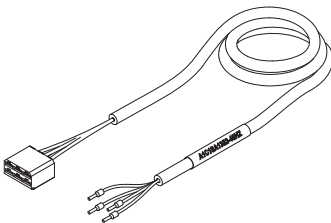

A1C1SA1352-XXXX

CONNECTION CABLE

EXPLODED VIEW - TAB. 3

A1N3S930-03-001 = \varnothing springs 0.3mm
 A1N3S930-04-001 = \varnothing springs 0.4mm
 A1N3S930-UN-001 = \varnothing springs 0.5mm

(STD Type)

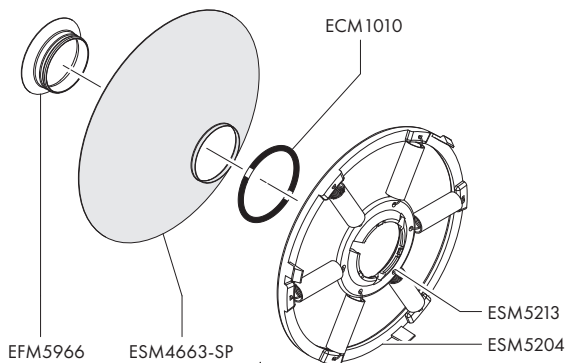

A1C1SA1436-03HZ (\varnothing 0.3mm GREEN)
 A1C1SA1436-04HZ (\varnothing 0.4mm RED)
 A1C1SA1436-UNHZ (\varnothing 0.5mm YELLOW - TRANSPARENT)

A1N3S930-UN-KLI = \varnothing springs 0.5mm

(Lamina Type)

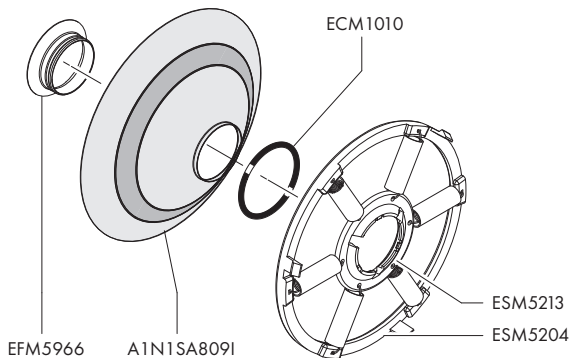

A1C1SA1436-UNHZ (YELLOW - TRANSPARENT)

EXPLODED VIEW - TAB. 4

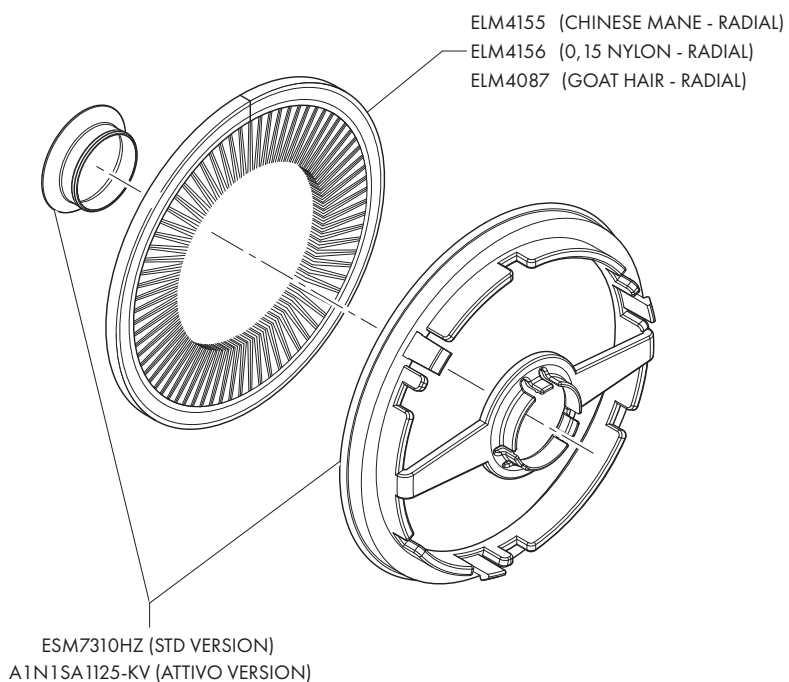

EXPLODED VIEW - TAB. 5.1

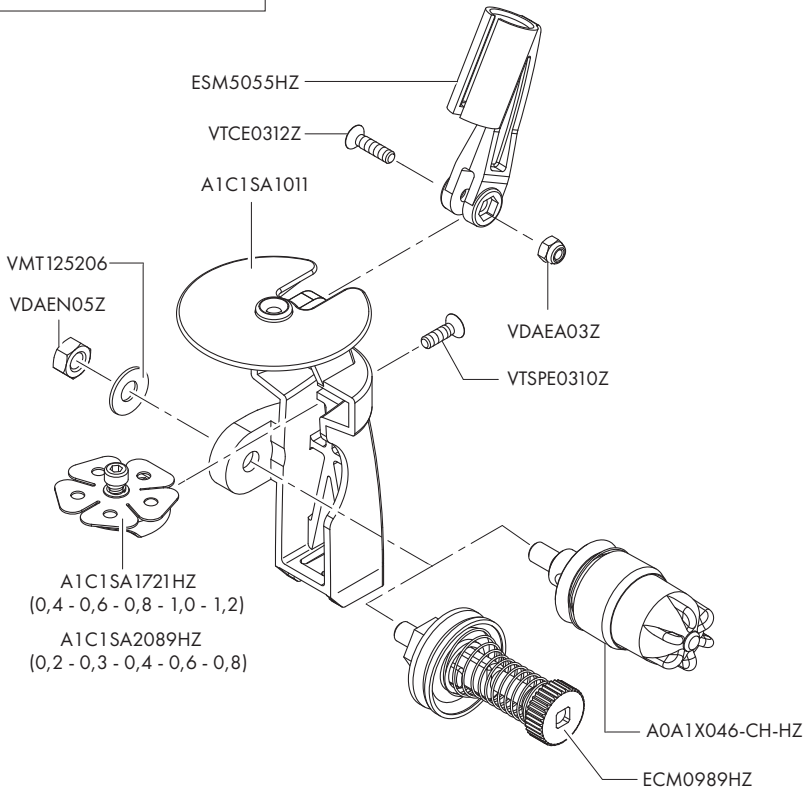
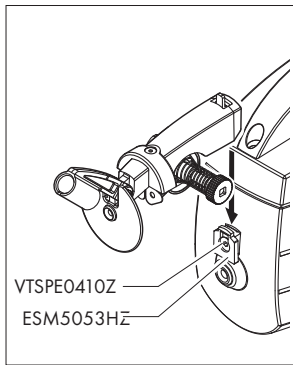

EXPLODED VIEW - TAB. 5.2

A1C3S900-T10HZ

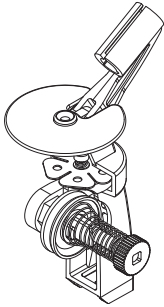

A1C3S900-S10HZ

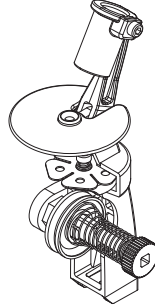

A1C2SA207-T10HZ

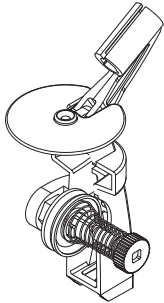

A1C2SA207-S10HZ

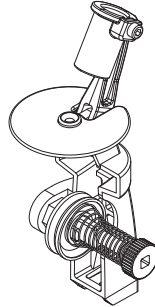

A1C3S881-ABHZ

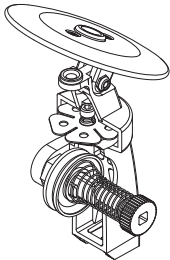

A1C3S888-ABHZ

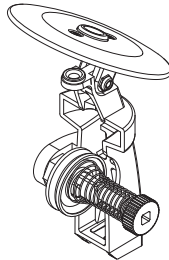

A1C3S946-T10HZ

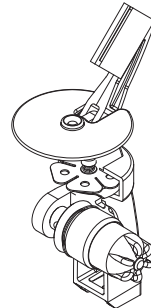

EXPLODED VIEW - TAB. 5.3

A1C3S929HZ

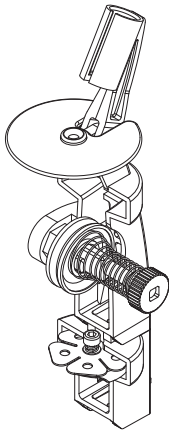

A1C3SA088-05-ABHZ

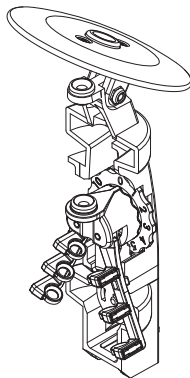

A1C3SA088-05-T10HZ

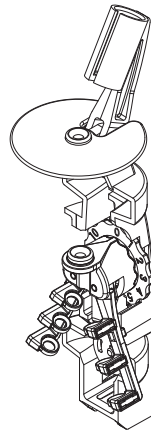

A1C3SA089-05-ABHZ

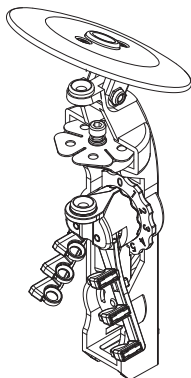

A1C3SA089-05-T10HZ

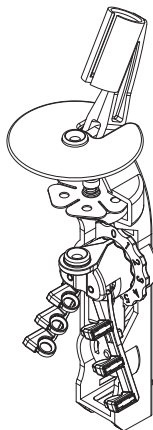

A1C3SA089-05-S10HZ

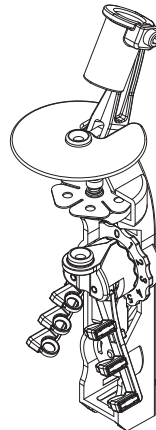

EXPLODED VIEW - TAB. 5.4

A1C3SA045-ABHZ

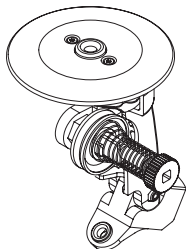

A1C3SA045-T10HZ

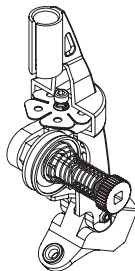

A1C3SA165-05-ABHZ

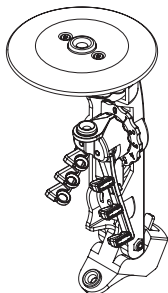

A1C3SA165-05-T10HZ

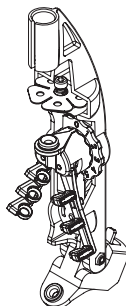

A1C1SA1119KE

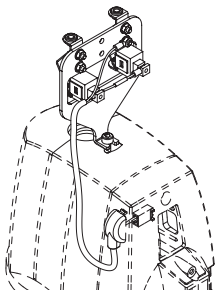

A1C1SA1119KE-3

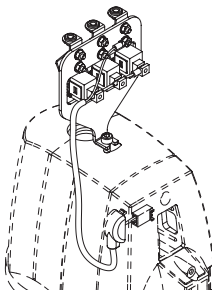

A1C1SA1119KE-4

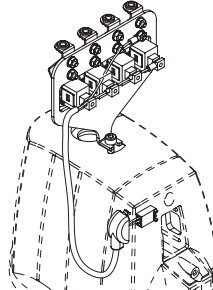

EXPLODED VIEW - TAB. 5.5

FEEDER WITHOUT ADDRESS

A1C4S844HZ-MCR

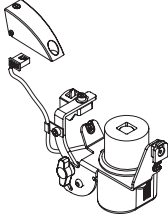

Horizontal Version basic

A1C4S844HZ-MCR-V

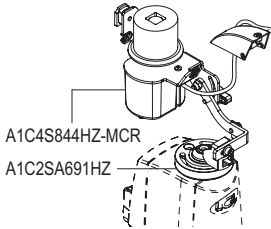

A1C4S844HZ-MCR
A1C2SA691HZ

Vertical Version basic

A1C4S846HZ

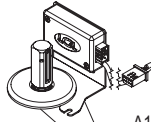

A1C3SA179HZ
A1C3SA181HZ

Wax End Upgrade Sensor

A1C5S060HZ-MCR

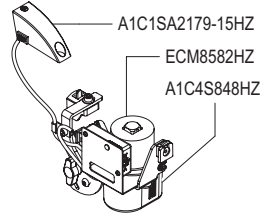

Horizontal Version complete

A1C5S060HZ-MCR-V

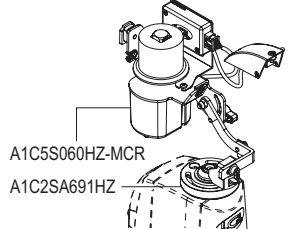

A1C5S060HZ-MCR
A1C2SA691HZ

Vertical Version complete

FEEDER WITH ADDRESS

A1C4S844HZ-XXX

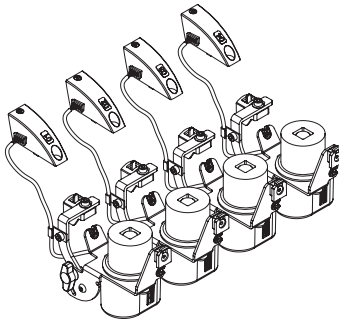

EXPLODED VIEW - TAB. 6

A2N1SA1321HZ-2P

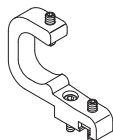

A1C1SA1368HZ



A2N2SA506HZ-2P

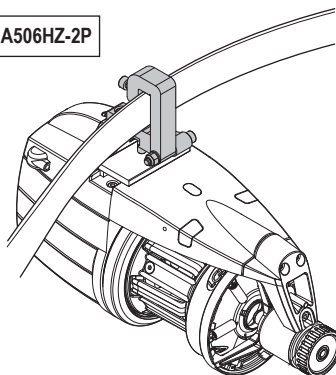
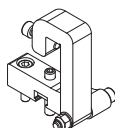

EXPLODED VIEW - TAB. 7.1

- A3N1SA566HZ** TRANSFORMER ASSEMBLY KIT
UP TO 8/10 FEEDERS (AC)
- A3N3SA035-05HZ** TRANSFORMER ASSEMBLY KIT
UP TO 5 FEEDERS (AC)
- A3N3SA036-05HZ** TRANSFORMER ASSEMBLY KIT
UP TO 5 FEEDERS - ECOMINI + SPIN2 (AC)

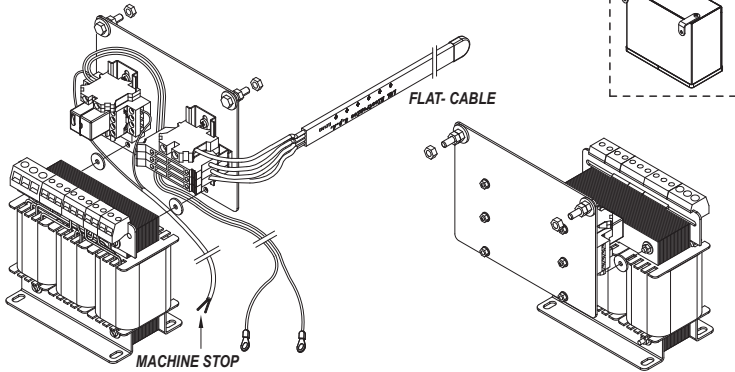

- A3N2S829HZ**
DERIVATION KIT

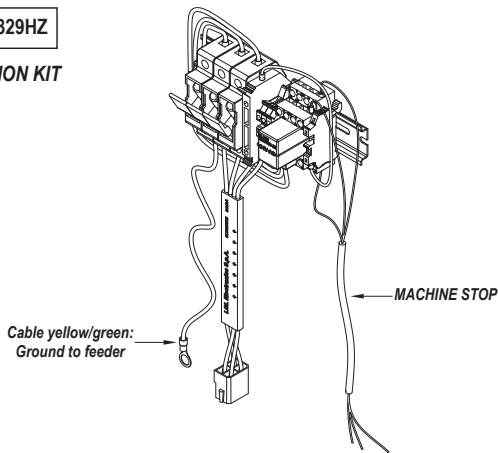

EXPLODED VIEW - TAB. 7.2

A3N2SA525GT08-48HZ DC KIT SEAMLESS UP TO 8

A3N2SA569-48HZ

STOP 320W

WITHOUT BOX

A3N2SA546-48HZ

CAN500W

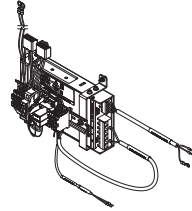

A3N3SA107-06-48HZ

CAN320W

A3N3SA107-12-48HZ

WITH BOX

CAN500W

A3N3SA107-24-48HZ

CAN1000W

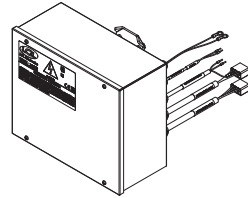

ECM6889

MEANWELL 320W 48V

ECM6919

MEANWELL 500W 48V

SE0653HZ

(TRANSFORMER ONLY)

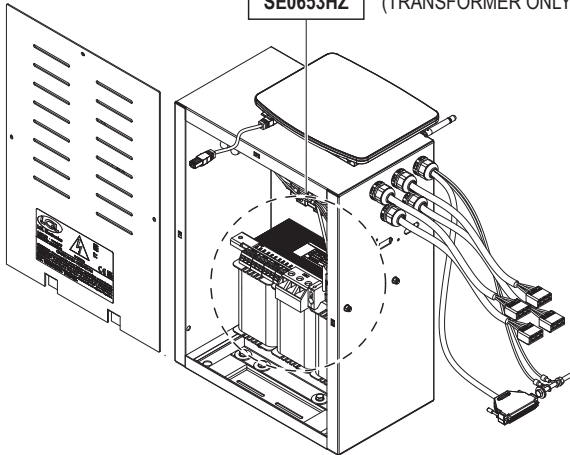

EXPLODED VIEW - TAB. 8.1

KYC TOUCH
A3N3SA111-STD

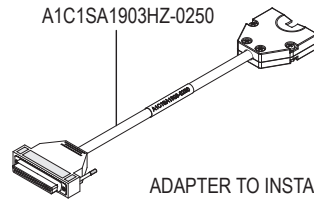
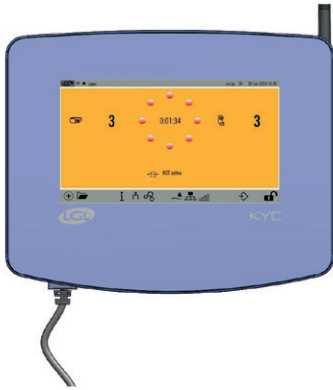

ADAPTER TO INSTALL
KYC A3N3SA111-STD
ON POWER KIT EQUIPPED
WITH KYC A3N2SA274-15

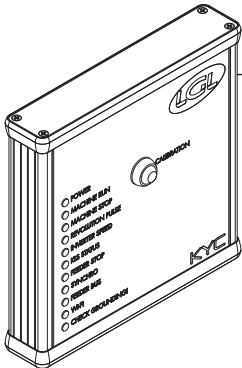

EXPLODED VIEW - TAB. 8.2

**USB CONNECT
A3N2SA365-15**

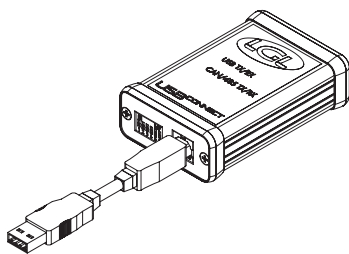

A7N1SA909-485

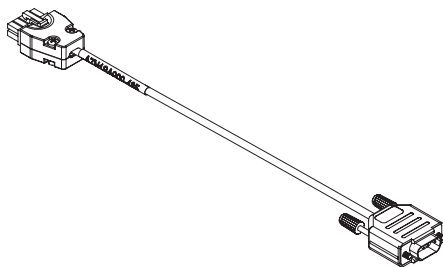

A1C1SA1656PW

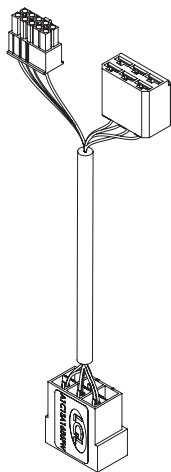

ECM6770 + USB

EXPLODED VIEW - TAB. 9.1

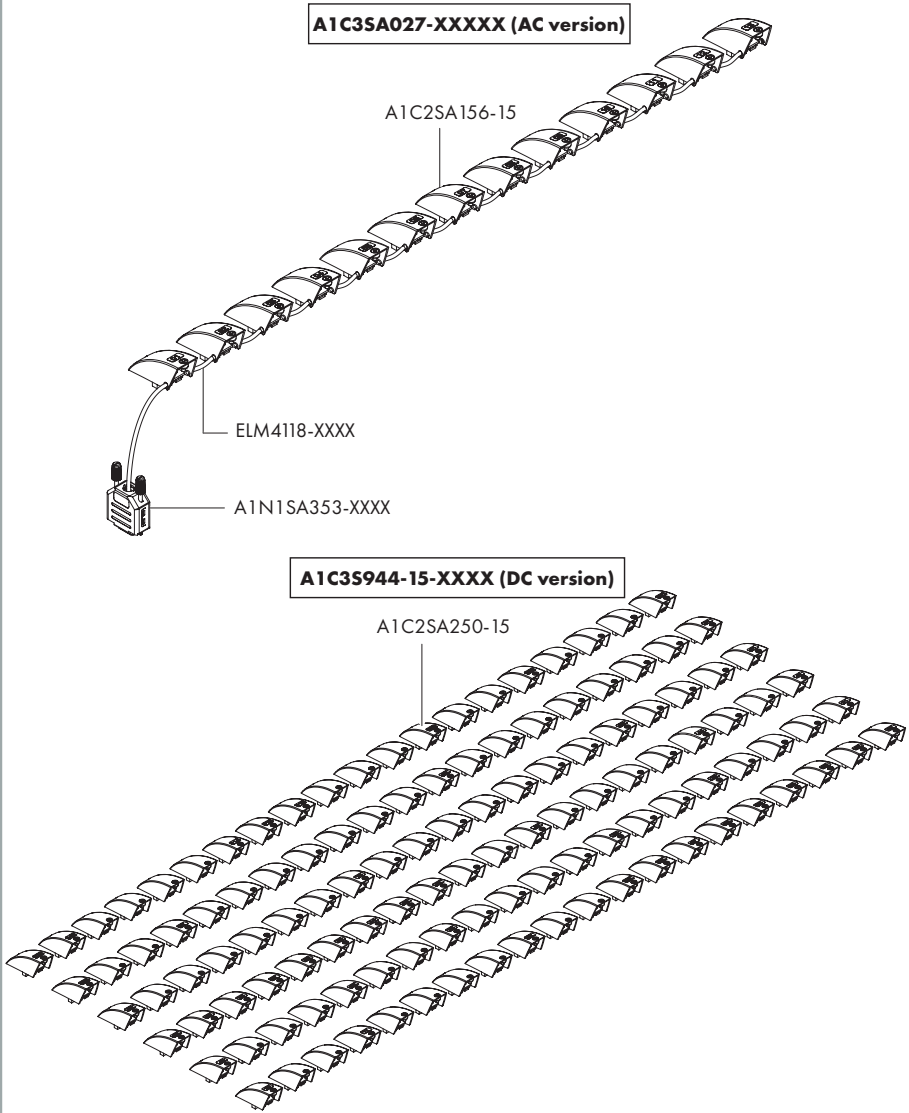

EXPLODED VIEW - TAB. 9.2

**AC version
A1C2SA156-15**

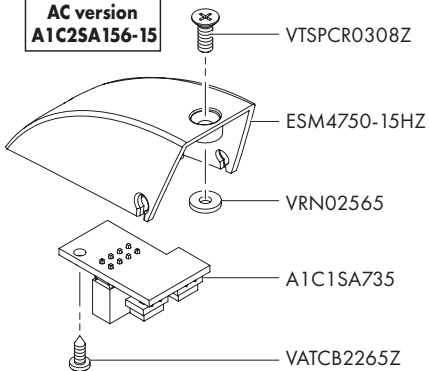

**DC version
A1C2SA250-15**

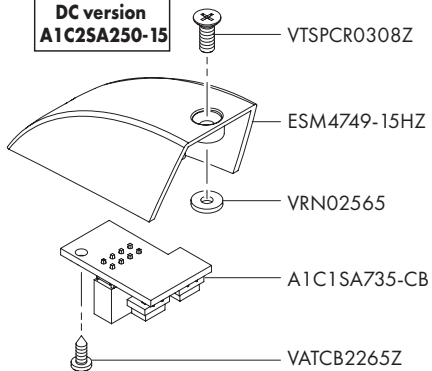

ELM4118-X

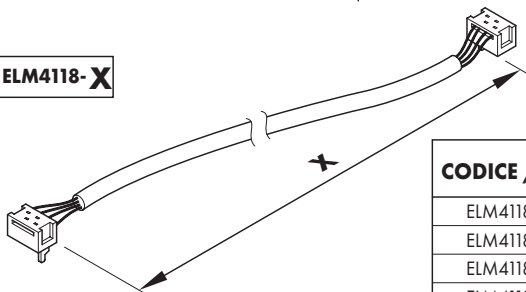

CODICE / CODE	X
ELM4118-0200	200
ELM4118-0500	500
ELM4118-1000	1000
ELM4118-1600	1600
ELM4118-2000	2000
ELM4118-3000	3000

A1N1SA353-X

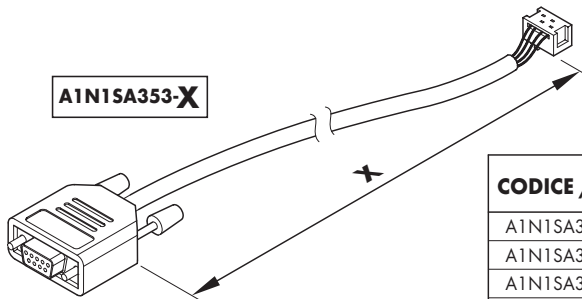

CODICE / CODE	X
A1N1SA353-1500	1500
A1N1SA353-2000	2000
A1N1SA353-4000	4000
A1N1SA353-6000	6000



L.G.L. Electronics S.p.A. reserve the right to alter in any moment one or more specifications of his machines for any technical or commercial reason without prior notice and without any obligation to supply these modifications to the machines, already installed.

T +39 035 733 408 **L.G.L. Electronics S.p.A.**
F +39 035 733 146 Via Ugo Foscolo, 156
lgI@gl.it 24024 Gandino (BG)
www.lgl.it Italy