

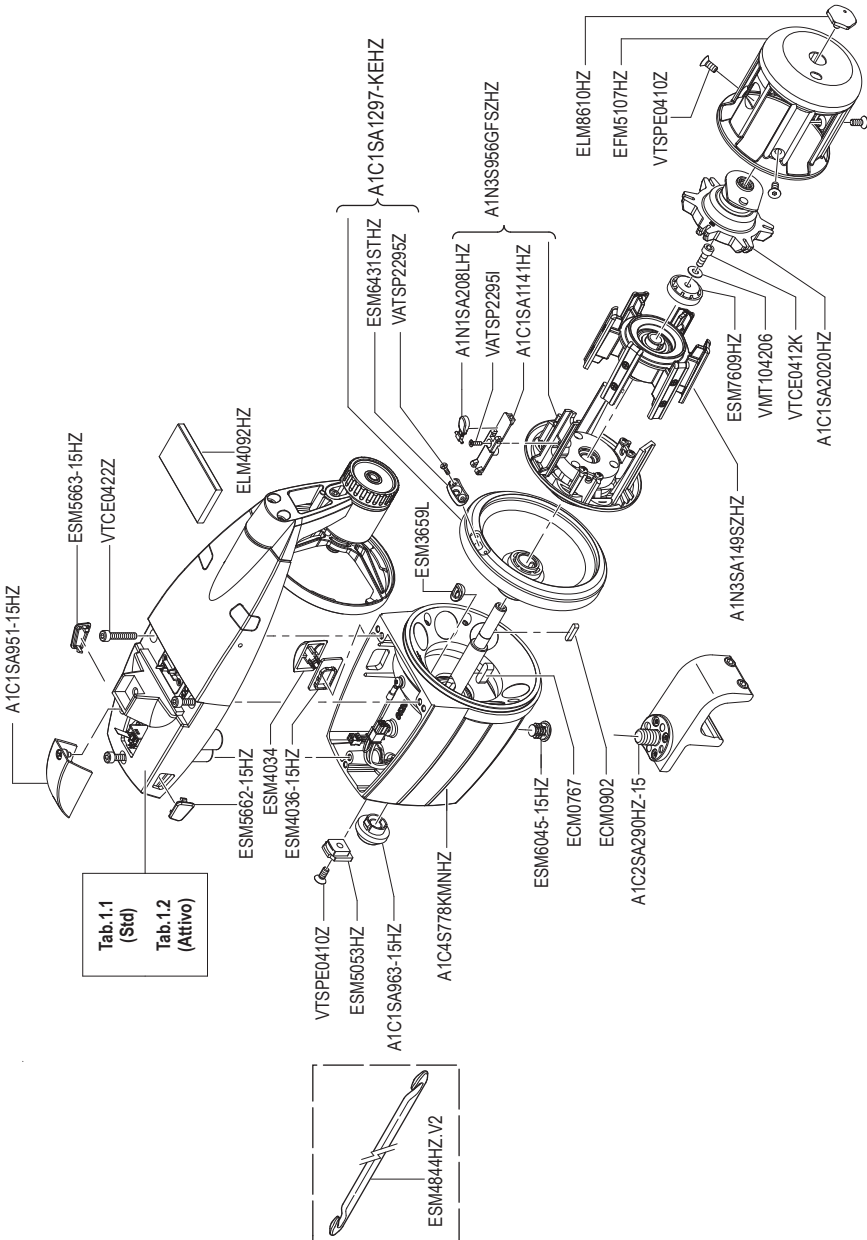

Rev. 1  
02/26

ECO<sup>MINI</sup>  
**SPARE PARTS**

## EXPLODED VIEW - TAB. 0



## EXPLODED VIEW - TAB. 1.1

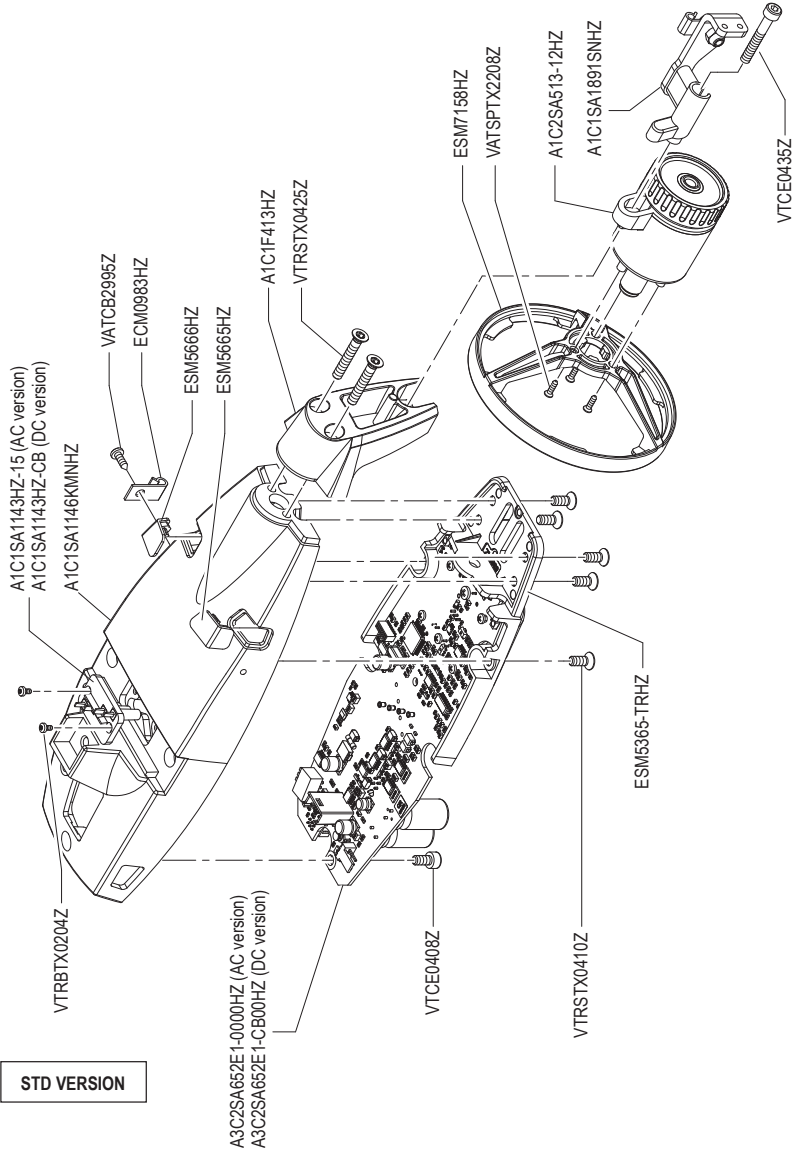

## EXPLODED VIEW - TAB. 1.2

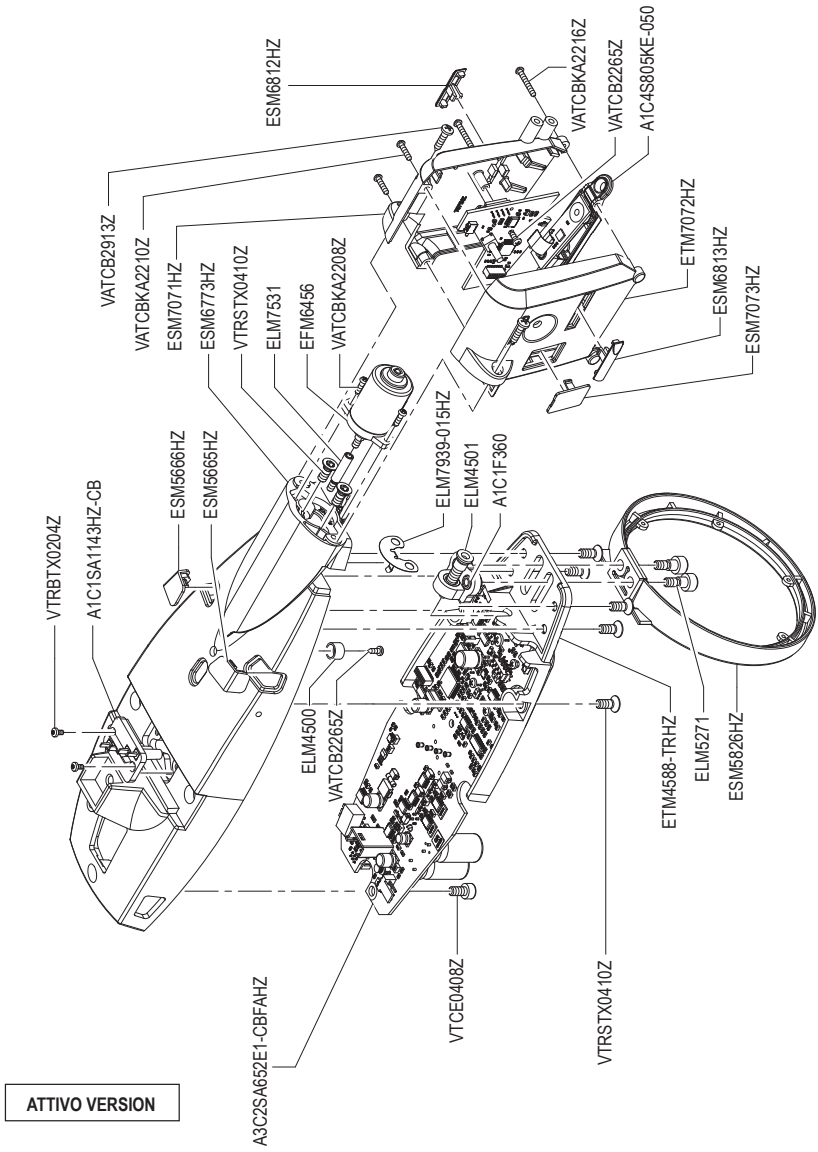

ATTIVO VERSION

## FLAT CABLE - TAB. 2.1

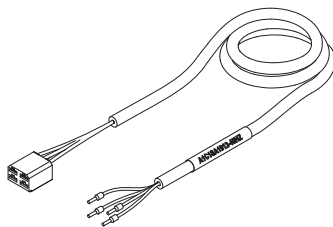
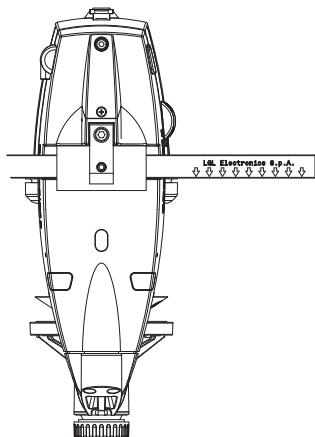

**A1C1SA1912-40HZ**

CONNECTION CABLE

CODICE	L=XXX (mm)
A1C1SA1000-10HZ	1000
A1C1SA1000-20HZ	2000
A1C1SA1000-30HZ	3000
A1C1SA1000-33HZ	3300
A1C1SA1000-38HZ	3800
A1C1SA1000-40HZ	4000
A1C1SA1000-48HZ	4800
A1C1SA1000-50HZ	5000
A1C1SA1000-60HZ	6000
A1C1SA1000-70HZ	7000
A1C1SA1000-80HZ	8000
A1C1SA1000M10HZ	10000
A1C1SA1000M12HZ	12000
A1C1SA1000M14HZ	14000

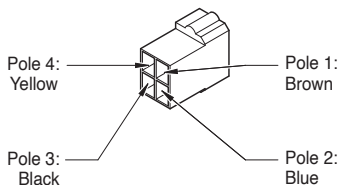
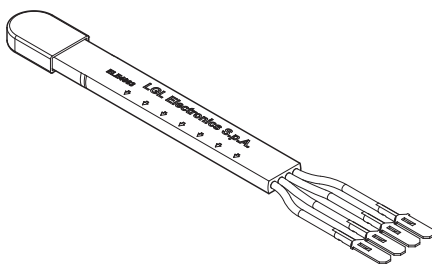

**LARGE DIAMETER AC**

## FLAT CABLE - TAB. 2.2

CODE (LEFT)	L=XXX (mm)
A1C2SA391H030L	3000
A1C2SA391H040L	4000
A1C2SA391H050L	5000
A1C2SA391H060L	6000
A1C2SA391H070L	7000
A1C2SA391H080L	8000
A1C2SA391H100L	10000
A1C2SA391H110L	11000
A1C2SA391H120L	12000
A1C2SA391H140L	14000
A1C2SA391H150L	15000

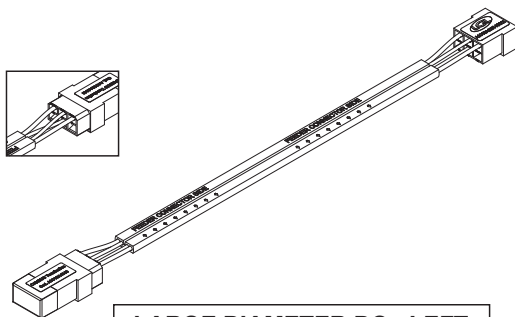

**LARGE DIAMETER DC - LEFT**

**EXTENSION CABLE: A1C1SA1251-XXHZ**

CODE (RIGHT)	L=XXX (mm)
A1C2SA391H030R	3000
A1C2SA391H040R	4000
A1C2SA391H050R	5000
A1C2SA391H060R	6000
A1C2SA391H070R	7000
A1C2SA391H080R	8000
A1C2SA391H100R	10000
A1C2SA391H110R	11000
A1C2SA391H120R	12000
A1C2SA391H140R	14000
A1C2SA391H150R	15000

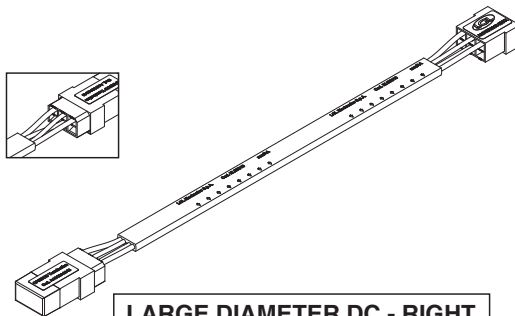

**LARGE DIAMETER DC - RIGHT**

**EXTENSION CABLE: A1C1SA1218-XXHZ**

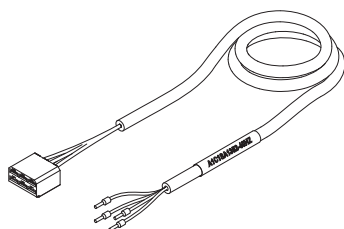

**A1C1SA1352-40HZ**

CONNECTION CABLE

## OUTPUT BRAKE - TWM - TAB. 3

A1N3S930-0300HZ =  $\varnothing$  springs 0.3mm

A1N3S930-0400HZ =  $\varnothing$  springs 0.4mm

A1N3S930-UN00HZ =  $\varnothing$  springs 0.5mm

**(STD Type)**

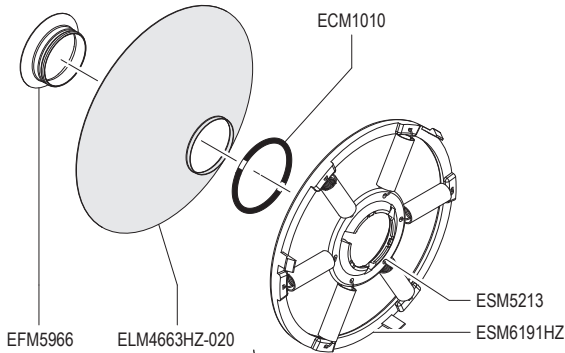

A1C1SA1436-03HZ ( $\varnothing$  0.3mm GREEN)

A1C1SA1436-04HZ ( $\varnothing$  0.4mm RED)

A1C1SA1436-UNHZ ( $\varnothing$  0.5mm YELLOW - TRANSPARENT)

A1N3S930-04KLHZ =  $\varnothing$  springs 0.4mm

**(Lamina Type)**

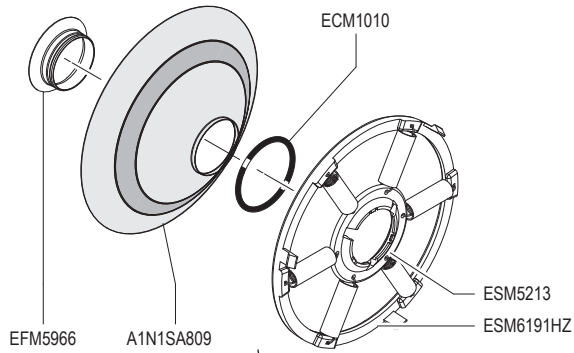

A1C1SA1436-UNHZ  
( $\varnothing$  0.5mm YELLOW - TRANSPARENT)

## OUTPUT BRAKE - BRISTLE BRUSH - TAB. 4

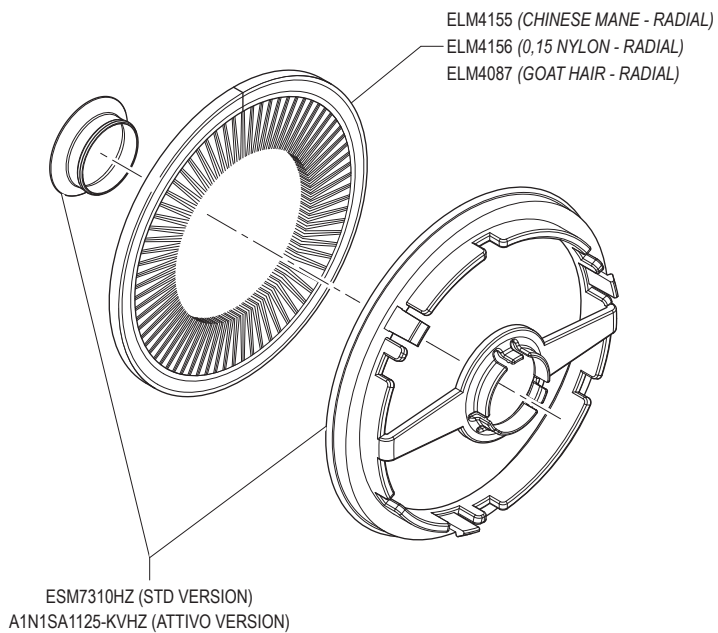

## INPUT BRAKE - TAB. 5.1

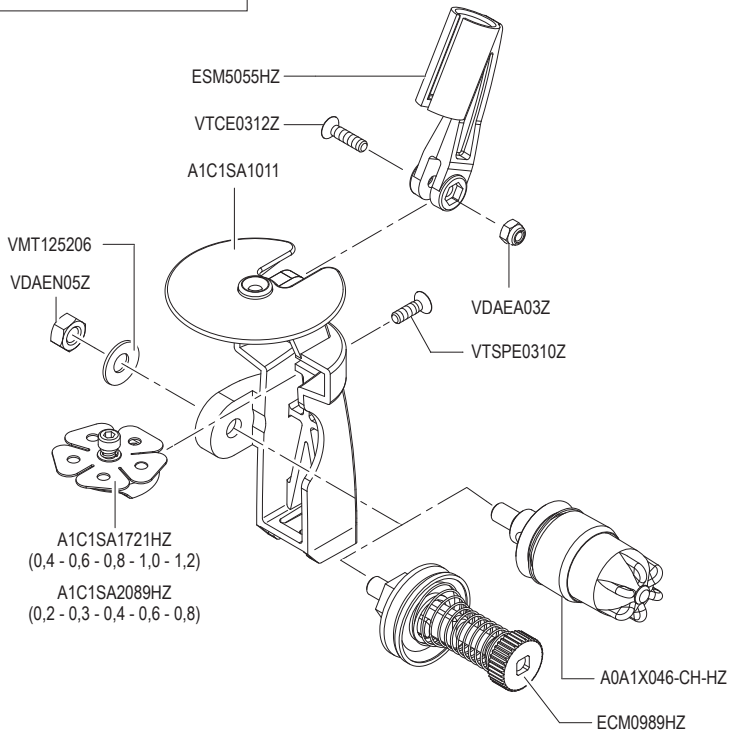
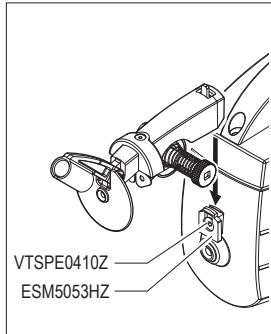

## INPUT BRAKE - TAB. 5.2

A1C3S900-T10HZ

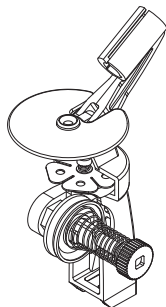

A1C3S900-S10HZ

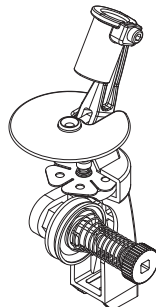

A1C2SA207-T10HZ

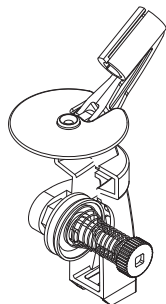

A1C2SA207-S10HZ

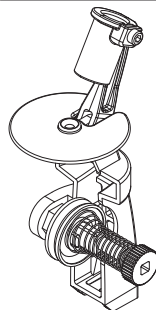

A1C3S881-ABHZ

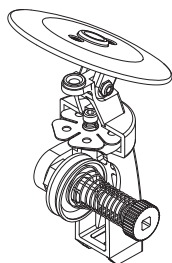

A1C3S888-ABHZ

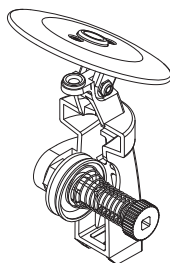

A1C3S946-T10HZ

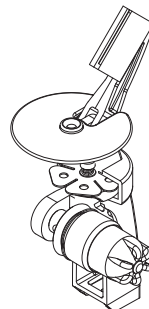

## INPUT BRAKE - TAB. 5.3

A1C3S929HZ

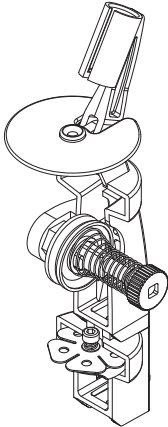

A1C3SA088-05-ABHZ

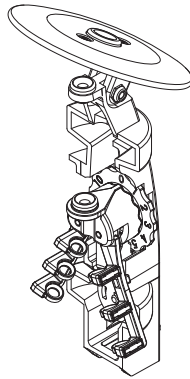

A1C3SA088-05-T10HZ

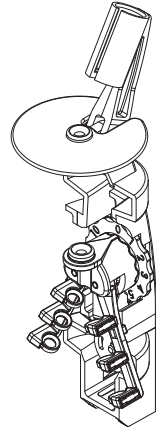

A1C3SA089-05-ABHZ

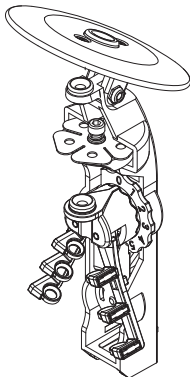

A1C3SA089-05-T10HZ

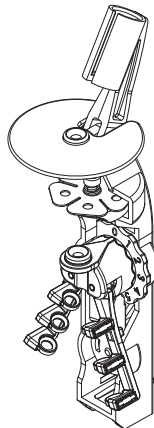

A1C3SA089-05-S10HZ

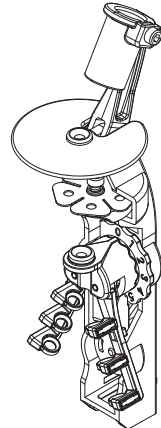

## INPUT BRAKE - TAB. 5.4

A1C3SA045-ABHZ

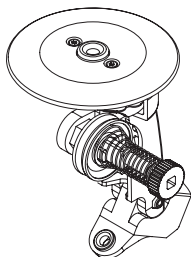

A1C3SA045-T10HZ

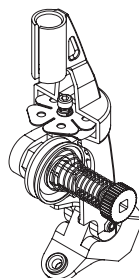

A1C3SA165-05-ABHZ

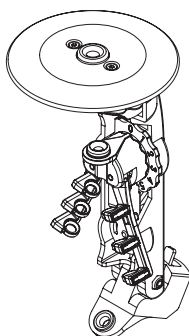

A1C3SA165-05-T10HZ

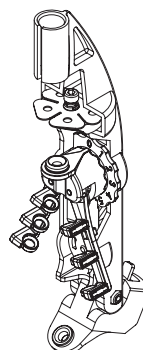

## WAXING UNIT - TAB. 5.5

### FEEDER WITHOUT ADDRESS

**A1C4S844HZ-MCR**

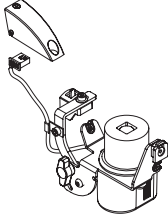

Horizontal Version basic

**A1C4S844HZ-MCR-V**

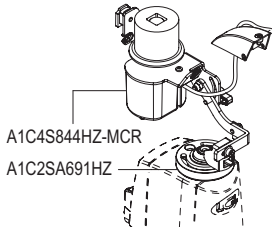

Vertical Version basic

**A1C4S846HZ**

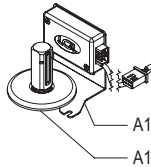

Wax End Upgrade Sensor

A1C3SA179HZ

A1C3SA181HZ

**A1C5S060HZ-MCR**

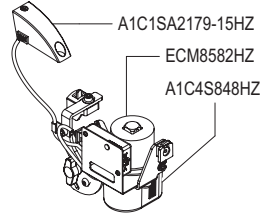

Horizontal Version complete

**A1C5S060HZ-MCR-V**

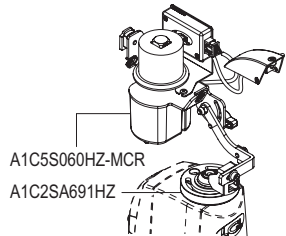

Vertical Version complete

### FEEDER WITH ADDRESS

**A1C4S844HZ-XXX**

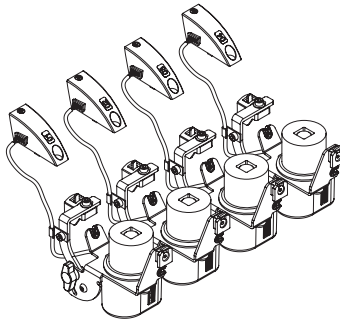

## CLAMP - TAB. 6

A2N1SA1321HZ-2P

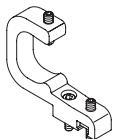

A1C1SA1368HZ



A2N2SA506HZ-2P

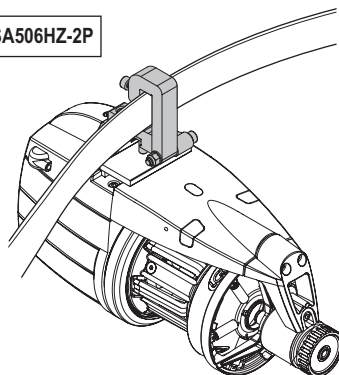
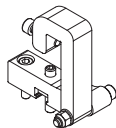

## POWER KIT - TAB. 7.1

- A3N1SA566HZ** TRANSFORMER ASSEMBLY KIT  
UP TO 8/10 FEEDERS (AC)
- A3N3SA035-05HZ** TRANSFORMER ASSEMBLY KIT  
UP TO 5 FEEDERS (AC)
- A3N3SA036-05HZ** TRANSFORMER ASSEMBLY KIT  
UP TO 5 FEEDERS - ECOMINI + SPIN2 (AC)

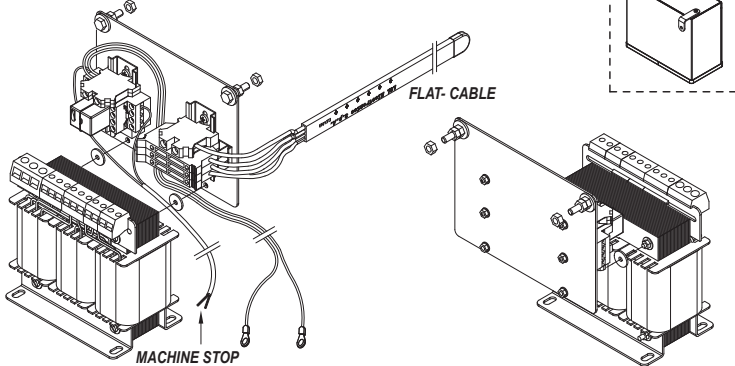

- A3N2S829HZ**  
**DERIVATION KIT**

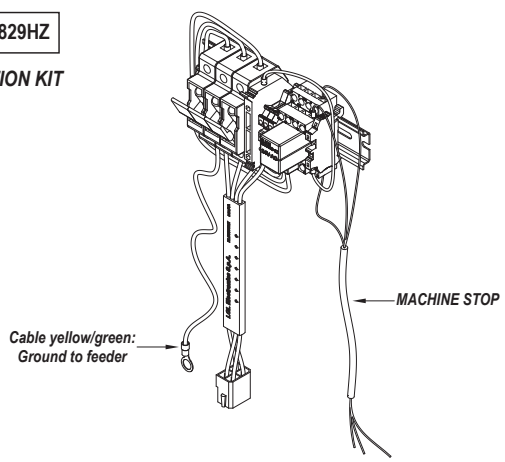

## POWER KIT - TAB. 7.2

**A3N2SA525GT08-48HZ** DC KIT SEAMLESS UP TO 8

**A3N2SA569-48HZ**

WITHOUT BOX

STOP 320W

**A3N2SA546-48HZ**

CAN500W

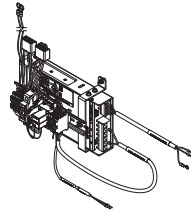

**A3N3SA107-06-48HZ**

CAN320W

**A3N3SA107-12-48HZ**

WITH BOX

CAN500W

**A3N3SA107-24-48HZ**

CAN1000W

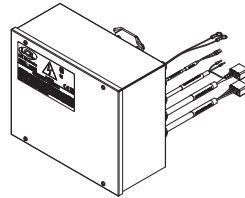

**ECM6889**

MEANWELL 320W 48V

**ECM6919**

MEANWELL 500W 48V

**SE0653HZ** (TRANSFORMER ONLY)

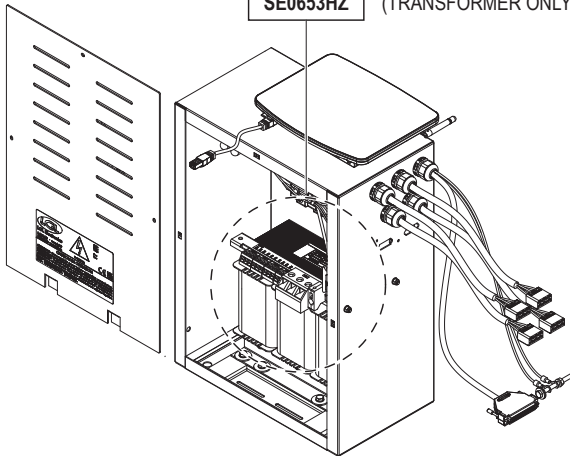

## USER INTERFACE - TAB. 8.1

KYC TOUCH  
A3N3SA111-STD

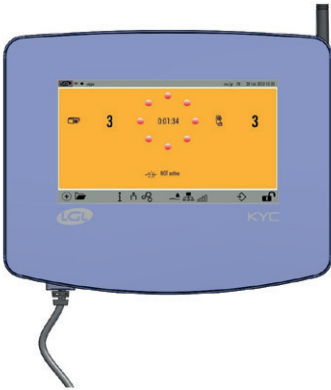

A1C1SA1903HZ-0250

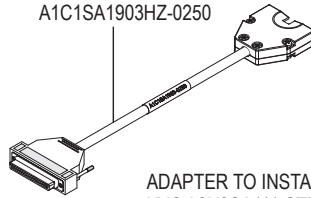

ADAPTER TO INSTALL  
KYC A3N3SA111-STD  
ON POWER KIT EQUIPPED  
WITH KYC A3N2SA274-15

KYC  
A3N2SA274-15

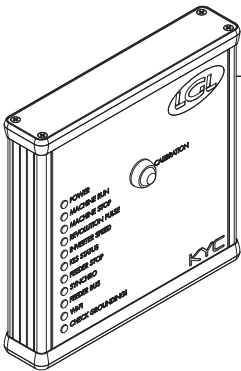

## USER INTERFACE - TAB. 8.2

USB CONNECT  
A3N2SA365-15

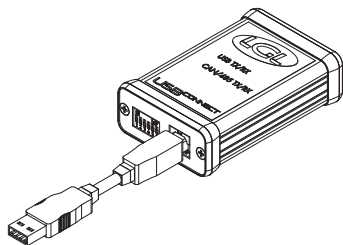

A7N1SA909-485

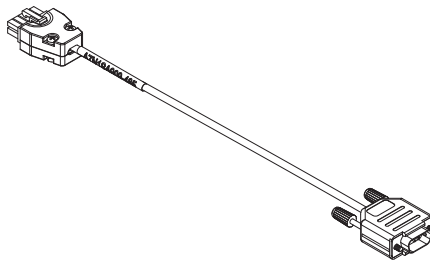

A1C1SA1656PWHZ

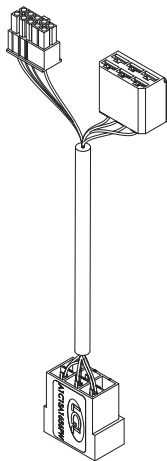

ECM6770 + USB

## KIT ADDRESS - TAB. 9.1

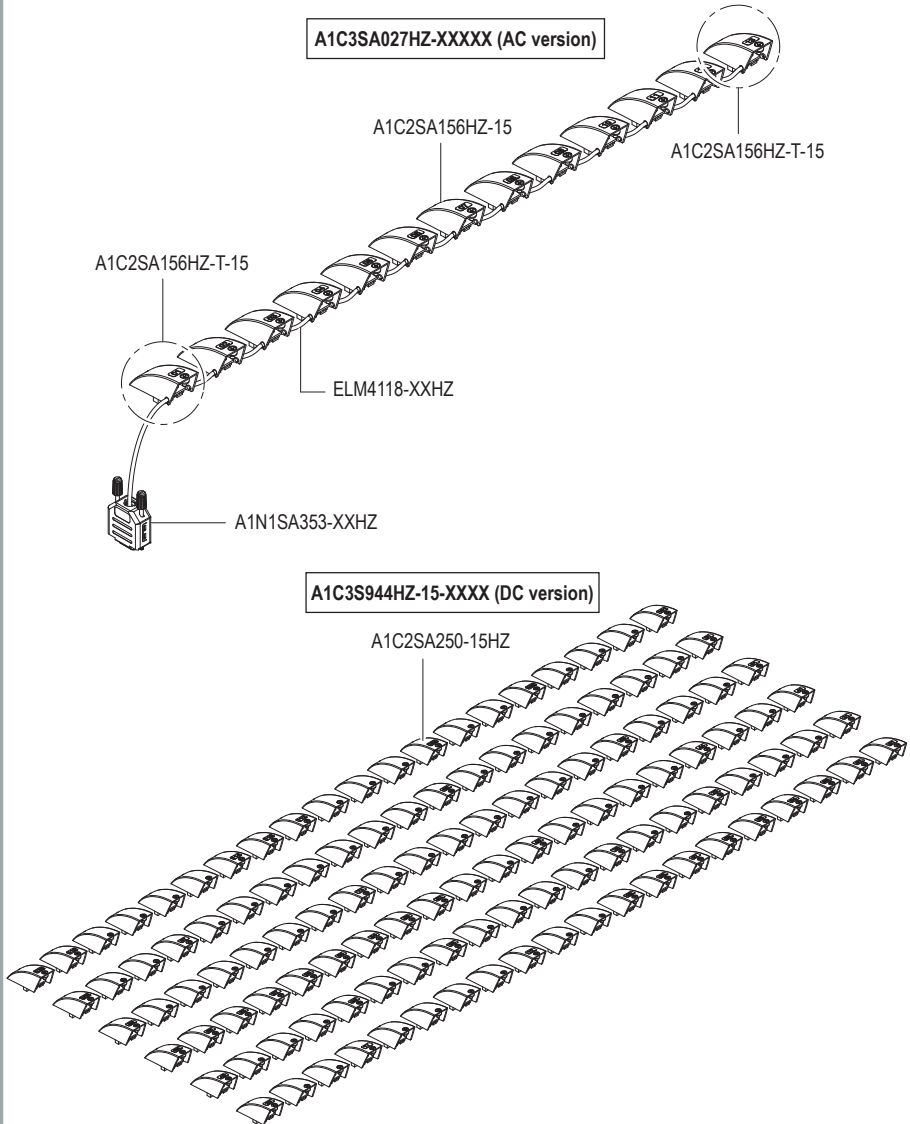

## KIT ADDRESS - TAB. 9.2

**AC version  
(TERMINATION)  
A1C2SA156HZ-T-15**

**AC version  
A1C2SA156HZ-15**

**DC version  
A1C2SA250-15HZ**

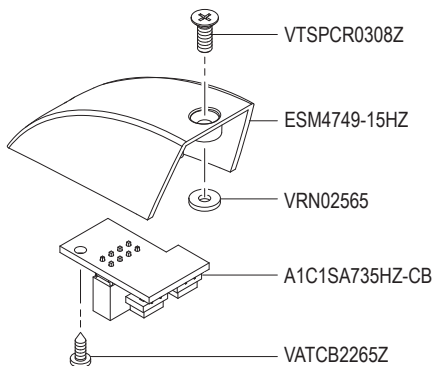
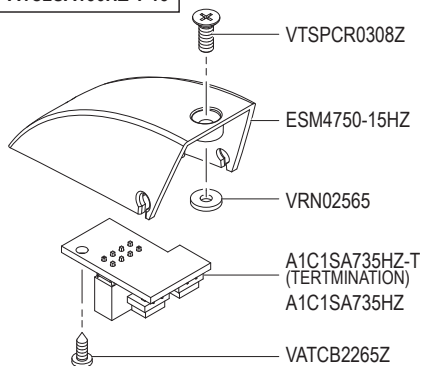

**ELM4118-XXHZ**

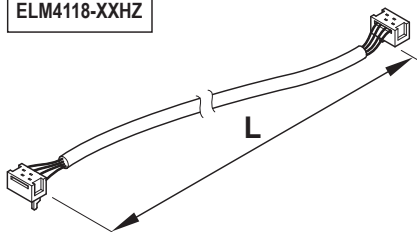

<b>CODICE / CODE</b>	<b>L</b>
ELM4118-02HZ	200
ELM4118-05HZ	500
ELM4118-10HZ	1000
ELM4118-14HZ	1400
ELM4118-16HZ	1600
ELM4118-20HZ	2000
ELM4118-30HZ	3000
ELM4118-80HZ	8000

**A1N1SA353-XXHZ**

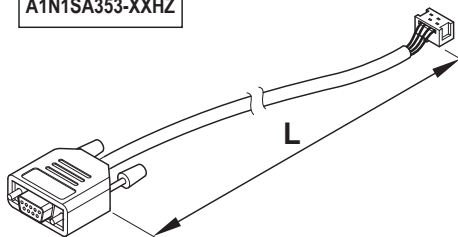

<b>CODICE / CODE</b>	<b>L</b>
A1N1SA353-15HZ	1500
A1N1SA353-20HZ	2000
A1N1SA353-40HZ	4000
A1N1SA353-60HZ	6000









**L.G.L. Electronics (Hangzhou) CO.Ltd.**

Building 17, 189 Hongcan Road,  
Hongken Nongchang, Economic Development Zone,  
Xiaoshan District, Hangzhou, Zhejiang  
T: +86-571-82877258  
F: +86-571-82877268  
Email: lglhz@lgl.it

爱吉尔电子(杭州)有限公司

浙江省杭州市萧山区经济技术开发区红垦农场红  
灿路189号17幢

电话: +86 0571-82877258

传真: +86 0571-82877268

邮箱: lglhz@lgl.it

**L.G.L. Electronics (Hangzhou) Co.,  
Ltd. FOSHAN Branch**

52-54 Jin Hong Street, Textile City, Xiqiao Town,  
Nanhai District, Foshan, Guangdong  
T: +86-757-86819435  
F: +86-757-86898258  
Email: yli@lgl.it

爱吉尔电子(杭州)有限公司佛山分公司

广东省佛山市南海区西樵轻纺城锦虹街52-54号

电话: +86-757-86819435

传真: +86-757-86898258

邮箱: yli@lgl.it

**L.G.L. Electronics (Hangzhou) Co.,Ltd. -  
SHANTOU service station**

A2108, Building 15, Dongsheng New World,  
Gurao Town, Chaoyang District, Shantou City,  
Guangdong Province, China  
T: +86-757-86819435  
F: +86-757-86898258  
Email: yli@lgl.it

爱吉尔电子(杭州)有限公司 - 汕头服务点

中国广东省汕头市潮阳区谷饶镇东升新世界15  
栋A2108

电话: +86-757-86819435

传真: +86-757-86898258

邮箱: yli@lgl.it

L.G.L. Electronics S.p.A. reserve the right to alter in any moment  
one or more specifications of his machines for any technical or  
commercial reason without prior notice and without any obligation  
to supply these modifications to the machines, already installed.